



HY-H58-X

SOLAR COLLECTOR INSTALLATION MANUAL



CONTENTS

Content:	Page
1. TECHNICAL DATA.....	2
2. CAUTIONS.....	3
3. SOLAR COLLECTOR TUBE.....	4
3.1 Components.....	4
3.2 Parameters.....	4
4. SOLAR COLLECTOR.....	5
5. INSTALLATION.....	6
5.1 Sloping Roof Installation.....	7
5.2 Flat Roof Installation.....	11
5.3 Solar Collector Parts Assembly.....	12
6. COLLECTOR COUPLING AND GROUNDING.....	13
6.1 Collector Coupling and Grounding.....	13
6.2 Sensor Faucet.....	13
6.3 Collector Coupling Demonstration.....	14
6.4 Pressure Drop Diagram.....	15
7. Solar System Demonstrate.....	16
7.1 Single Coil System.....	16
7.2 Double Coils System.....	16
7.3 Double Tanks System.....	17
7.4 Multi-function combined system.....	17

1. Technical Data

Model	HY-H58-10	HY-H58-12	HY-H58-15	HY-H58-18	HY-H58-20	HY-H58-22	HY-H58-24	HY-H58-25	HY-H58-30
Absorber area(m ²)	1.975	2.37	2.963	3.555	3.95	4.345	4.74	4.938	5.925
Aperture area(m ²)	0.943	1.132	1.415	1.698	1.887	2.075	2.264	2.358	2.830
Gross area(m ²)	1.401	1.671	2.077	2.482	2.752	3.022	3.293	3.428	4.103
Gross size L x W (mm)	1985*726	1985*866	1985*1076	1985*1286	1985*1426	1985*1566	1985*1706	1985*1776	1985*2126
Weight empty	34.4	40.8	50.4	60	66.4	72.8	80.4	83.6	99.6
Fluid capacity(L)	0.62	0.74	0.93	1.12	1.24	1.36	1.49	1.55	1.86
Hydraulic connections	G1"male								
flow rate	0.10L/min.tube								
Max. flow rate	20L/min								
Max. operation pressure	6bar								
Test pressure	9bar								
Heat transfer fluid	The mixture of Glycol-water								
Permissible wind load	25m/s								
Permissible snow load	500mm								

2. CAUTIONS

- 2.1 Gloves and Eyes protection must be used when handling glass tubes.
Avoid scratching or any sudden shock to tubes;
- 2.2 Under all circumstances that tubes are exposed to the sun over a long period without heat extraction from the system;
- 2.3 Unpack and install the tubes only after the manifold unit has been installed and all pipes work had been completed and the system is filled.
(Avoid high temperature of empty manifold to affect system efficiency);
- 2.4 During installation of the tubes, the pump should be switched on;
- 2.5 If the system no work long time, it's better to shadow the solar collector;
- 2.6 Don't install by hanger to avoid dropping and hurting human;
- 2.7 Install the solar collector with **25°~70°** angle.
- 2.8 In hot water applications, a heat exchanger should be used between the collector and the hot water storage tank to ensure a long and trouble free service life (calcium deposition).
- 2.9 When heating a swimming pool or spa, a heat exchanger should be used between the pool and the collector.

3. SOLAR COLLECTOR TUBE

3.1 Components

1: Heat Pipe

Transfer the thermal energy from the bottom to the condenser efficiently and rapidly;

2: Spring

Make the Cone condenser to touch exchanged copper pipe more close, Increase more transfer efficiency ;

3: Cover

Fix up heat pipe in the middle of glass tubes and protect the thermal energy lost from the glass tube;

4: Conductive Aluminum fins

Transfer the thermal energy from the glass inner wall to the heat pipe rapidly;

5: Vacuum layer

Vacuum layer between inner glass tube and outer tube ensures good heat protection.

6: CPC reflector

CPC reflector between inner tube and outer tube, more vacuum space for CPC to collect sunshine in Maximal Efficiency

7: Solar glass tube

Smaller diameter inner tube designed, more transfer efficiency, less transfer heat resistance.

Smaller diameter designed for end tube, easy for installation.

8: Getter

This part seems like Mirror color which means the vacuum layer keeps well.

9: Cap

Protect the glass tube in transportation and movement

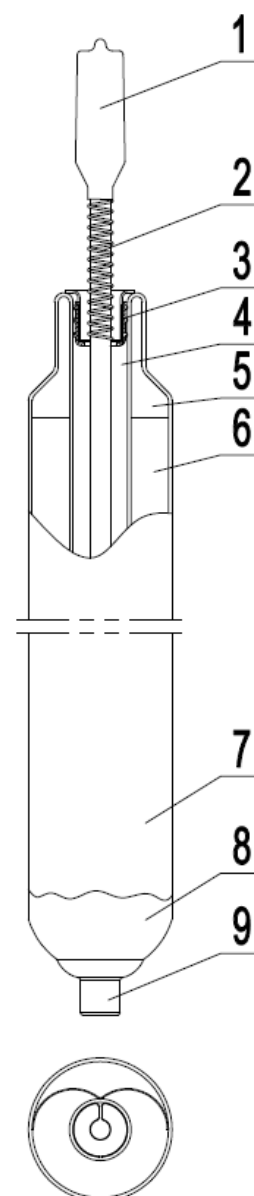

3.2 Parameters

SOLAR COLLECTOR TUBE PARAMETERS						
Absorption	Emission	Glass transmission	Vacuum	Tiptop temp.	Low temp. durability	Wind durability
≥95%	≤8%	≥92%	≤3.5×10 ⁻³ P a	250°C	-35°C	25m/s

4. SOLAR COLLECTOR

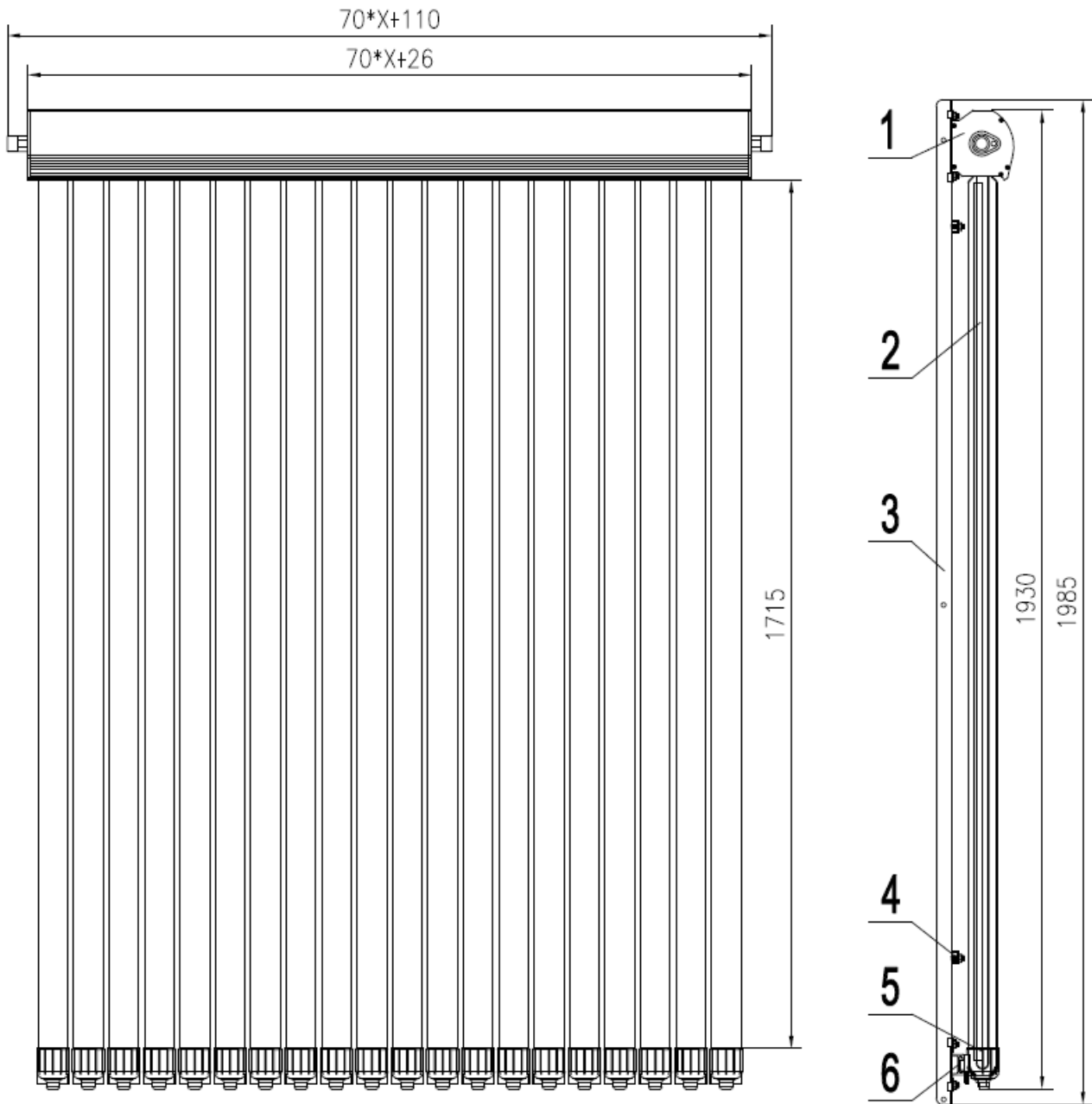

- 1. Manifold box 2. Solar vacuum tube 3. Front track
- 4. Front Brace 5. Tube bottom holder 6. Bottom track

5. INSTALLATION

Select a suitable position for the collector. It should be face most to the sun without any shadow around. Recommended angle of tilt is the same as your geographical latitude. The roof should be strong enough to hold the collect weight.

Tighten all of bolts to ensure that bottom track and manifold are in line.

Installation way: Sloping roof installation: A;

Sloping roof installation: B;

Flat roof installation: C

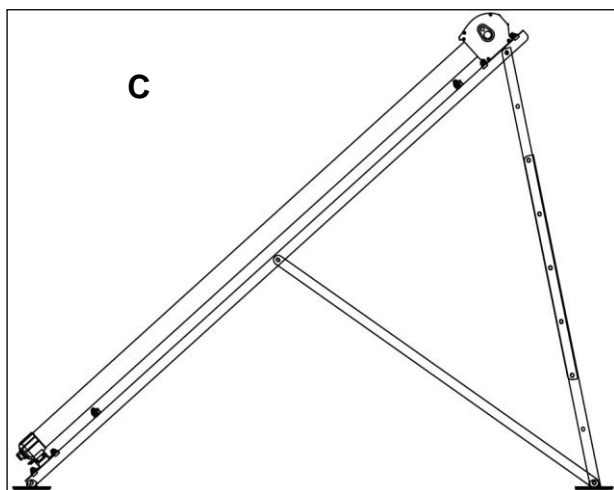
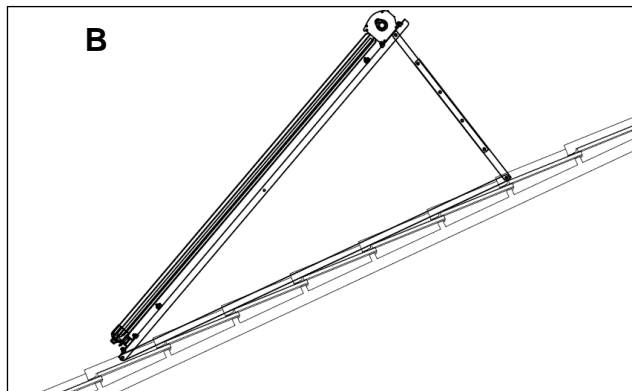
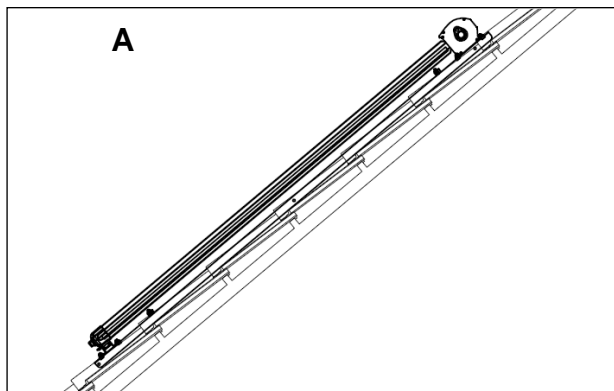

5.1 SLOPING ROOF INSTALLATION

Select a suitable installation way according to roof angle,
local latitude and tile shape.

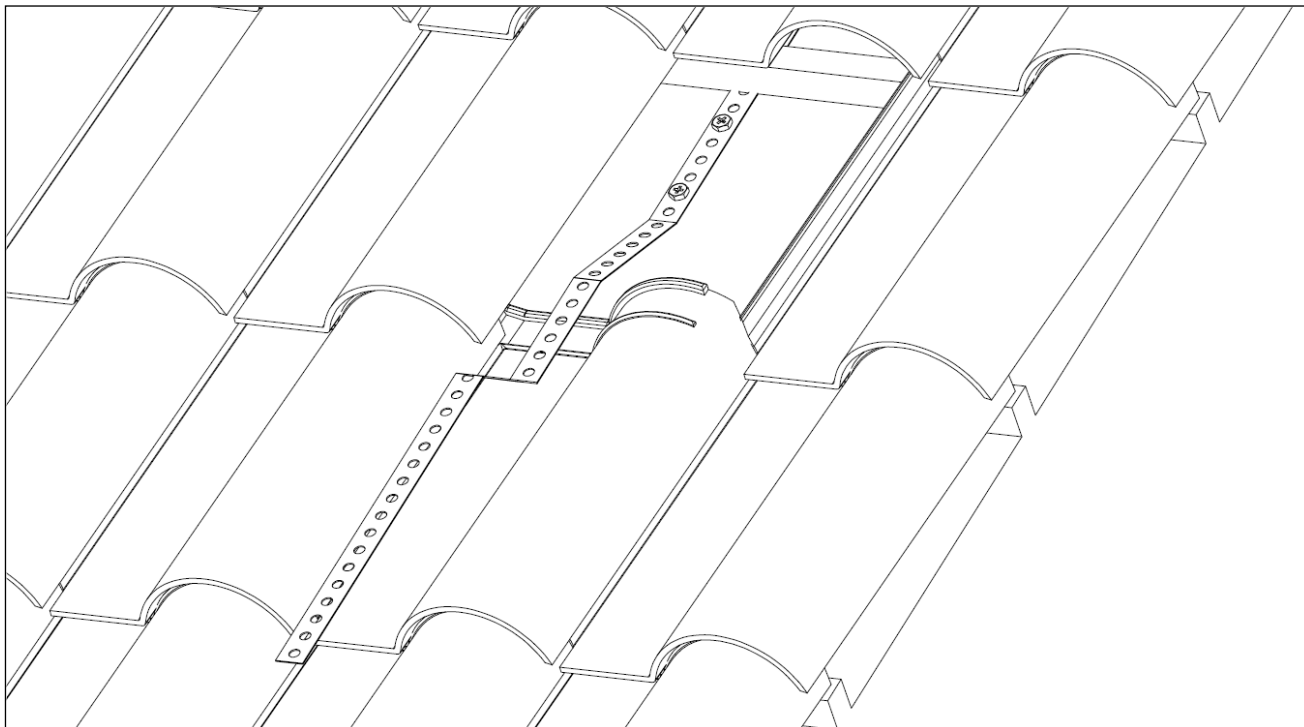

Note: Select suitable place in the roof, Fix Strip Hook in the roof firstly (choose different Roof Hook according to different structure roof), The roof should be strong enough to hold the collect weight, the product must be installed by professional licensed personnel

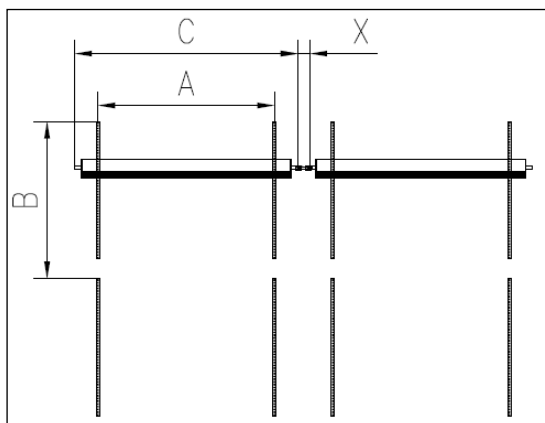

HY-H58-10~25

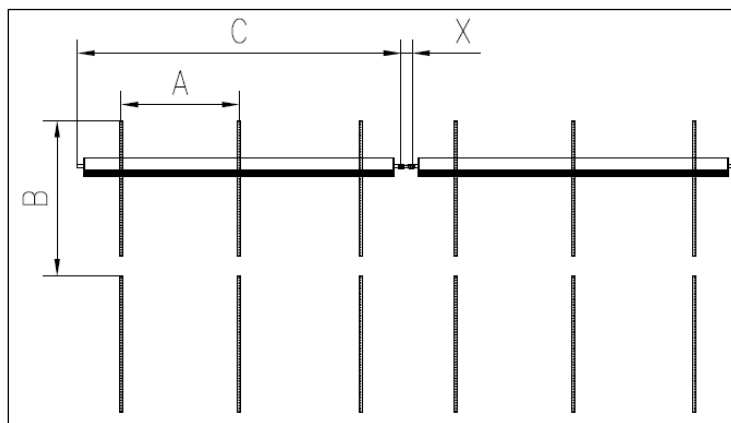

HY-H58-30

Model	Horizontal bands spacing (A)	Vertical bands spacing (B)	集热器总宽度 (C)
HY-H58-10	665mm	1000~1800mm	810mm
HY-H58-12	805mm		950mm
HY-H58-15	1015mm		1160mm
HY-H58-18	1225mm		1370mm
HY-H58-20	1365mm		1510mm
HY-H58-22	1505mm		1650mm
HY-H58-24	1645mm		1790mm
HY-H58-25	1715mm		1860mm
HY-H58-30	1032.5mm		2210mm

Note: X Length of flexible connector
 A Installed with 24mm Strip Hook
 B Installed with 20mm Strip Hook

5.1.1 Sloping roof installation A

This installation way is that solar collector is installed in the Sloping roof directly, please make sure that this angle of sloping roof is same as recommended installation angle of solar collector

(Recommended installation angle of solar collector = geographical latitude $\pm 10^\circ$)

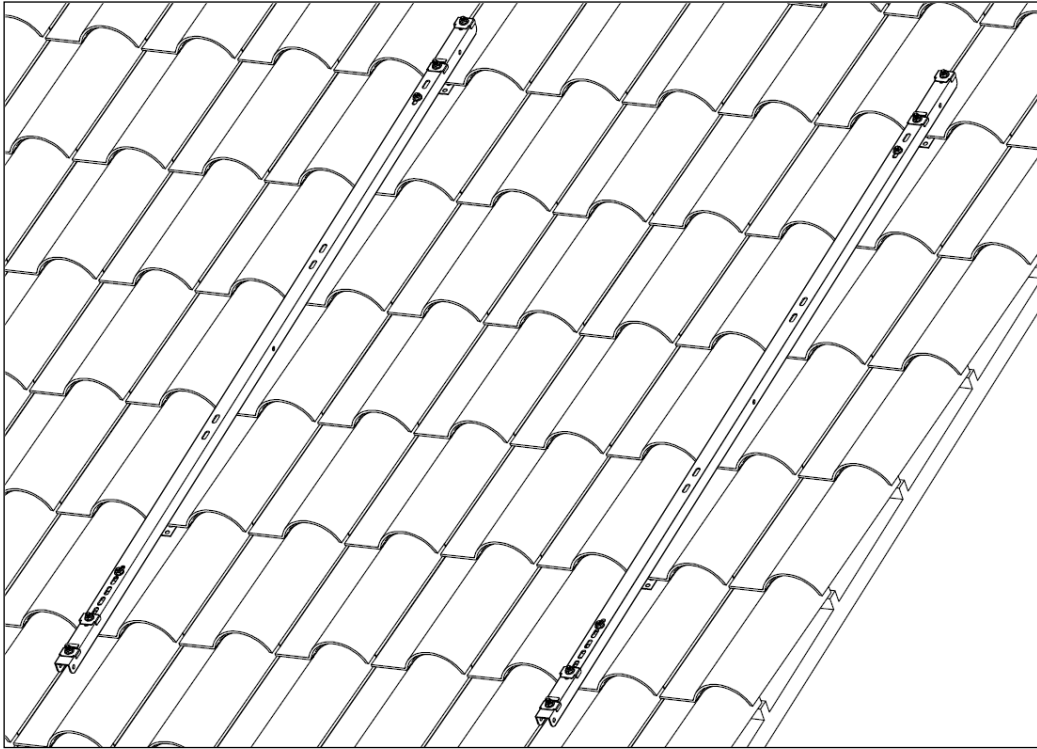

Fix the front tracks in the sloping roof which are with suitable width between front tracks.

5.1.2 Sloping roof installation B

This installation way is that When the angle of sloping roof is less than recommended installation angle of solar collector, you can use the sloping roof frame to adjust the installation angle to the best working angle of solar collector. Installation step and example are as below :

HY-H58-10~25

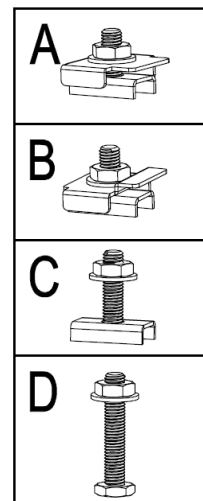
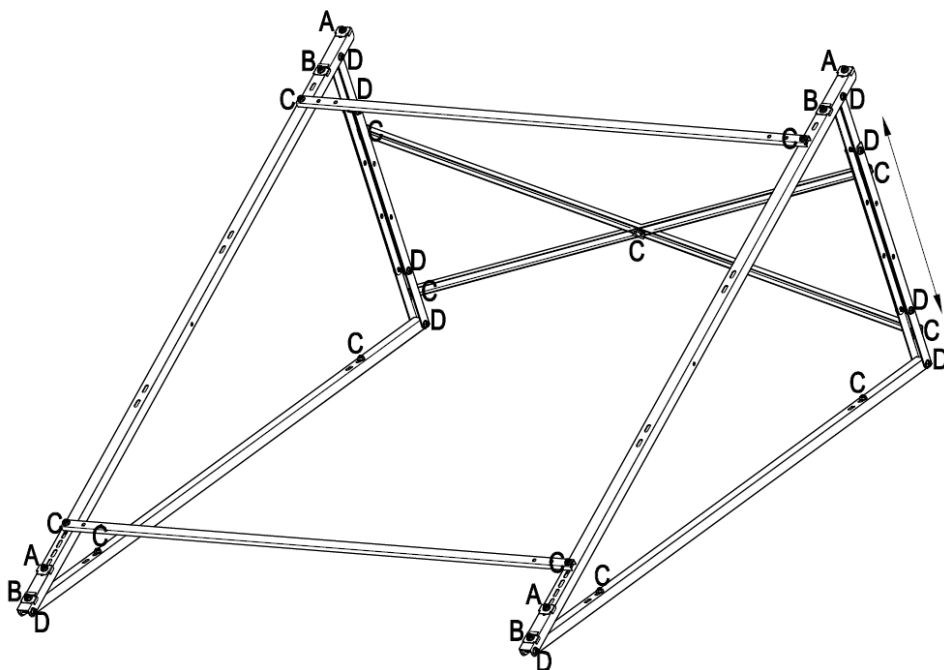

HY-H58-30

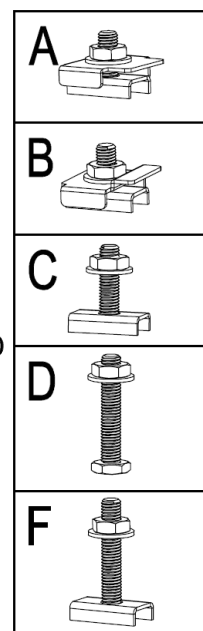
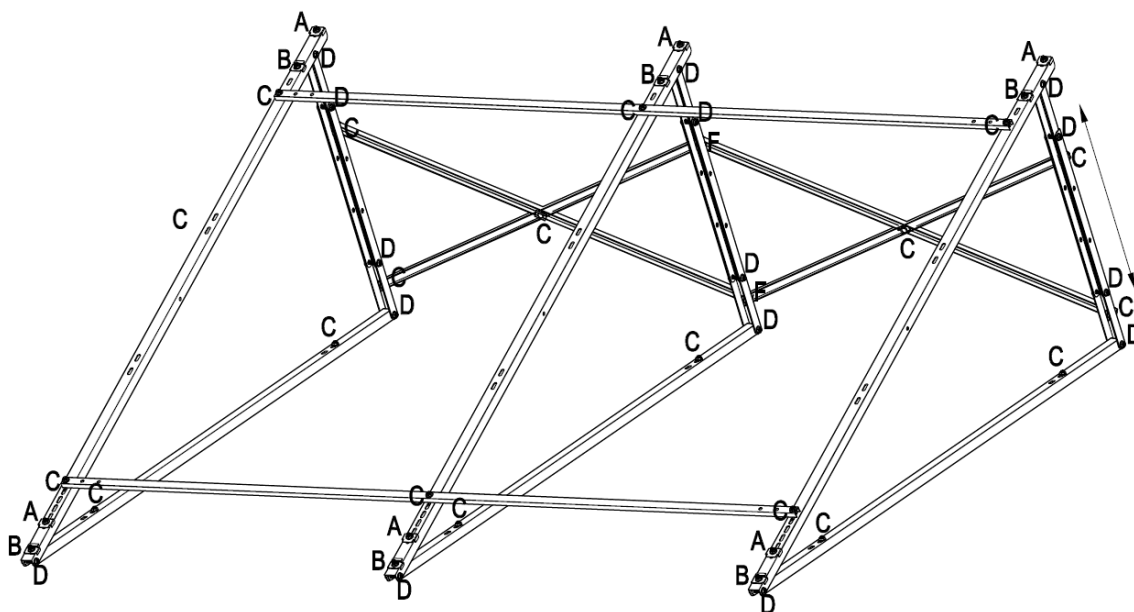

Adjustable angle range : 25°—30°—35°

5.2 Flat roof installation C

This installation way is that solar collector is installed in the Flat roof
 (Recommended installation angle of solar collector = geographical latitude $\pm 10^\circ$)

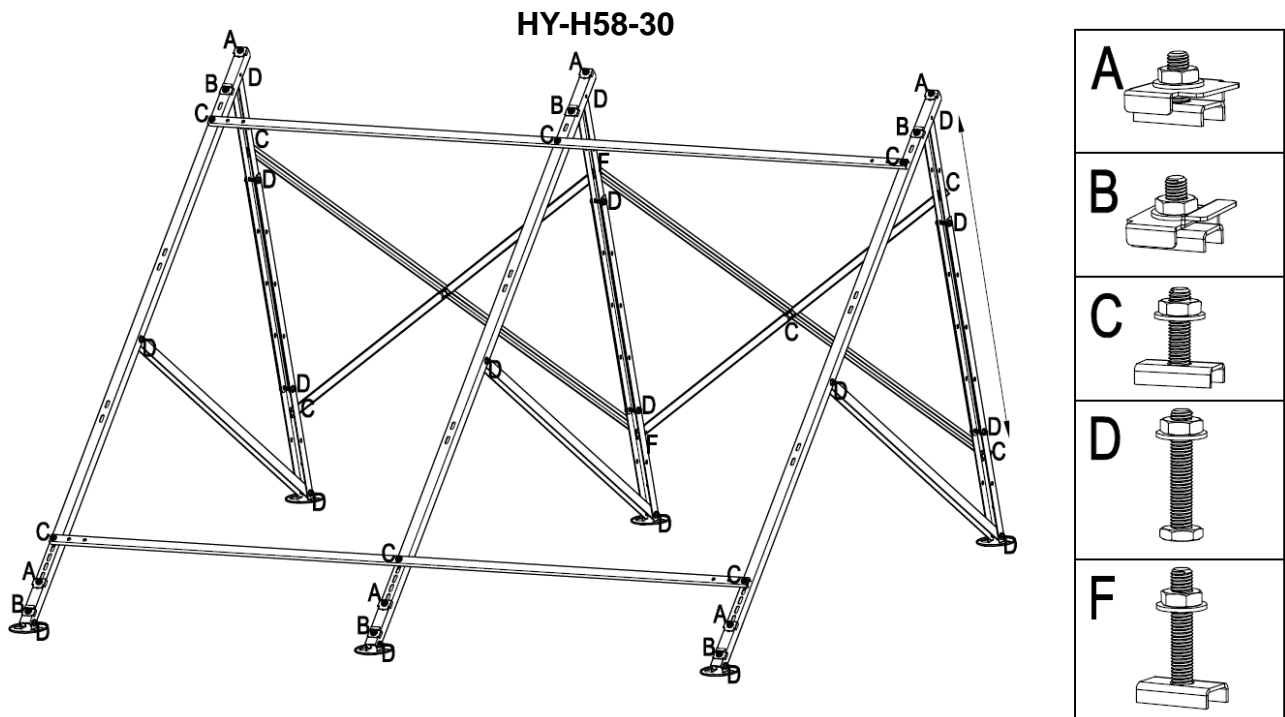
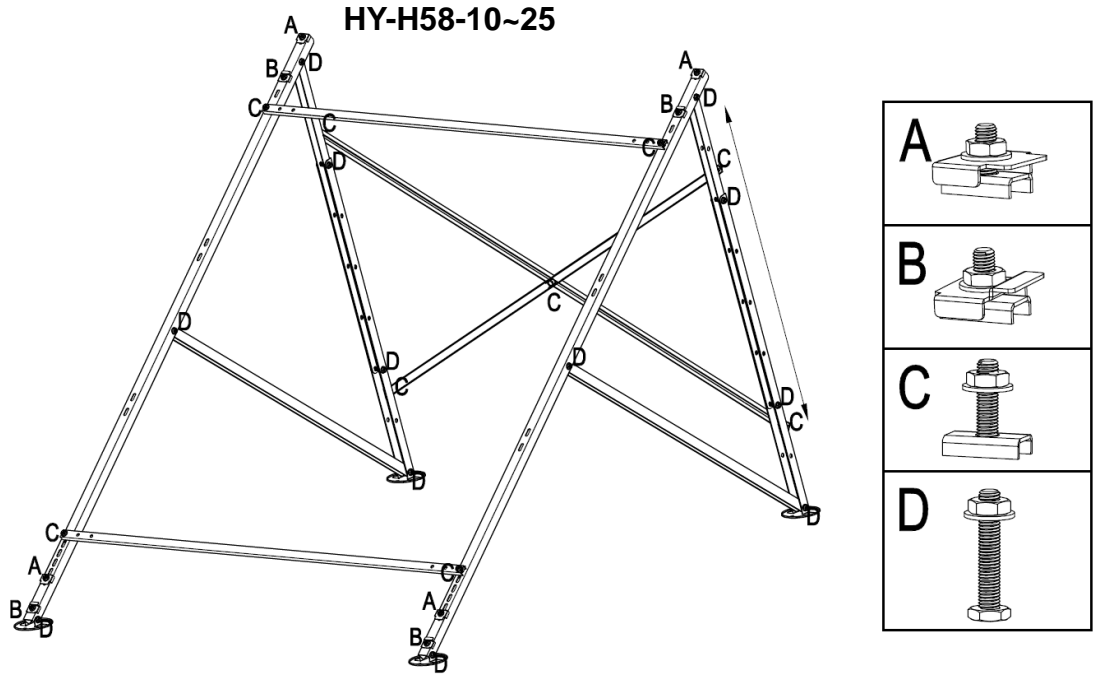

Adjustable angle range : $36^\circ - 42^\circ - 50^\circ - 58^\circ - 68^\circ$

Note: Fix the feet tightly with bolts after the complete assembly.

5.3 Solar Collector Parts Assembly

I Install manifold and glass tubes :

A. Fix manifold and bottom track in the front track;

B. Pull out heat pipe which is distance 300mm length from cover of glass tube , paste the silicon glue uniformly on the cone condenser of heat pipe , then insert heat pipe in the hole of copper pipe of manifold (Step1), continue rotated the glass tube to make sure the glass tube is inserted in manifold deeply (Step2);

C. Cover tube bottom holder to the bottom of tube, then insert the tube bottom holder to bottom track, upward push the tube bottom holder, when you listen a “click”, then finish this step.

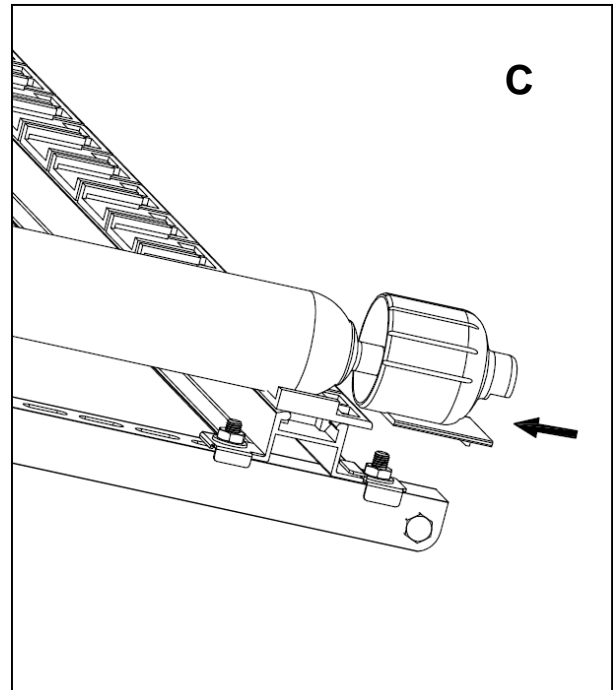
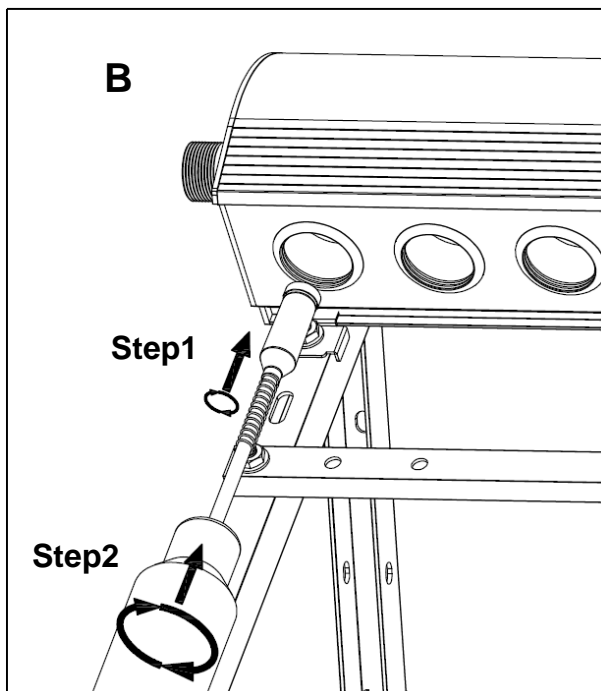
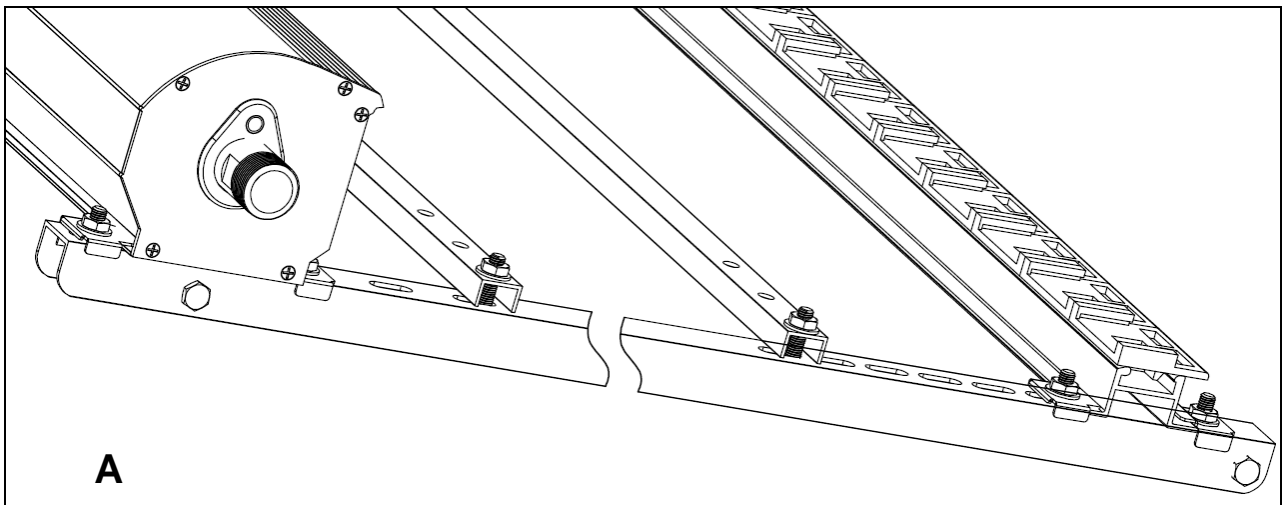

Remark: Installation all of parts carefully. Don't damage the powder painting on the tracks. Don't break the glass tubes.

6. COLLECTOR COUPLING AND GROUNDING

6.1 Collector Coupling and Grounding

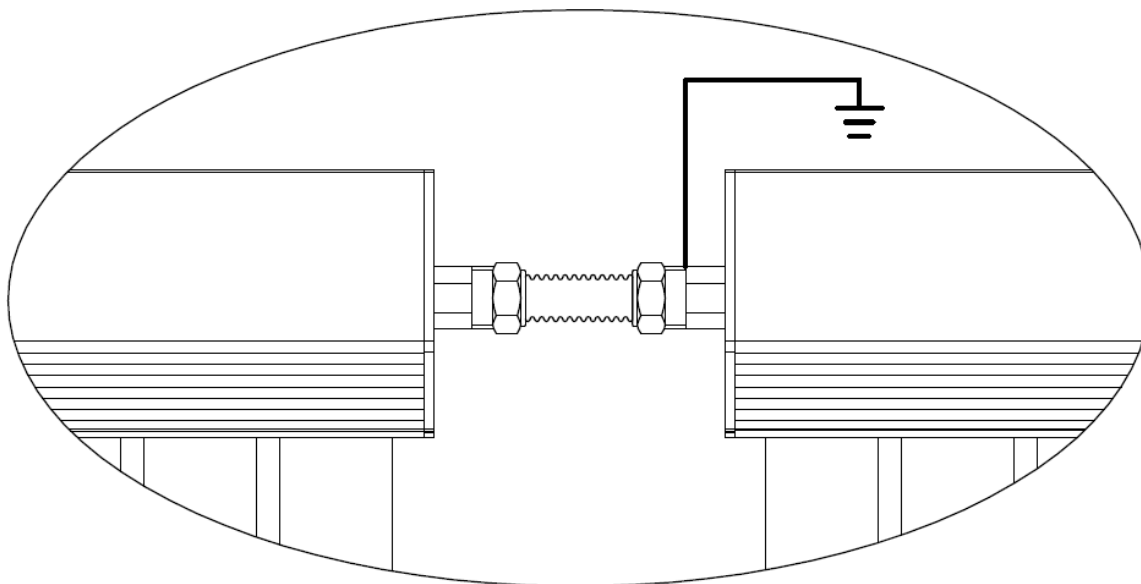

To connect solar collectors with flexible connections

*Recommended max tubes no. in series ≤ 180 pcs

Note: Please make inlet or outlet grounding for Lightning Conduction.

6.2 Sensor Faucet Connection

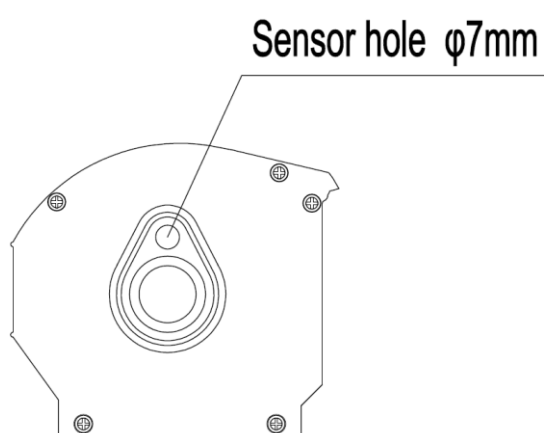

Put the sensor in the sensor hole of the outlet of the collector as above figure.

6.3 Collector Coupling Demonstration

Collector array with 20m² absorber

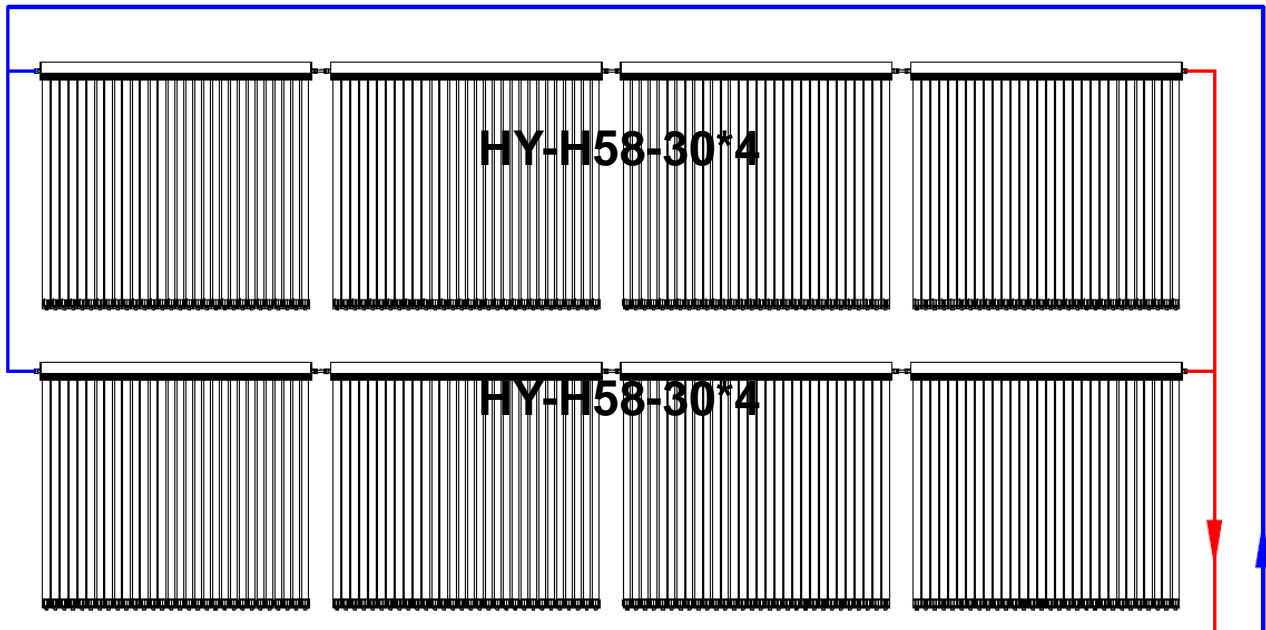

6.4 Pressure Drop Diagram:

HY-H58-10:

The pressure drop diagram of collector HY-H58-30 is showed as below.

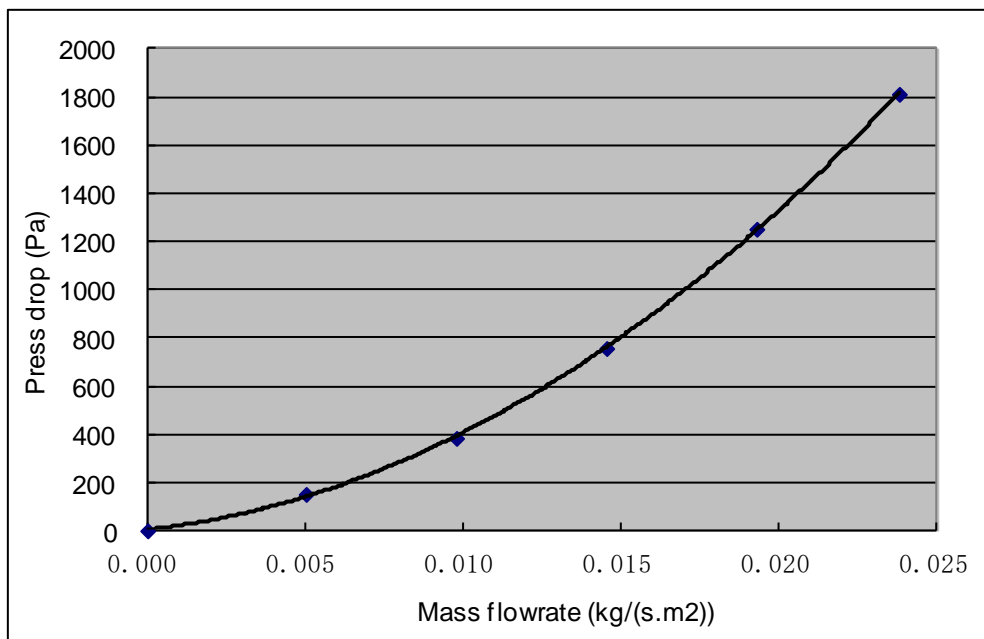

7. Solar System Demonstrates

7.1 Single Coil System

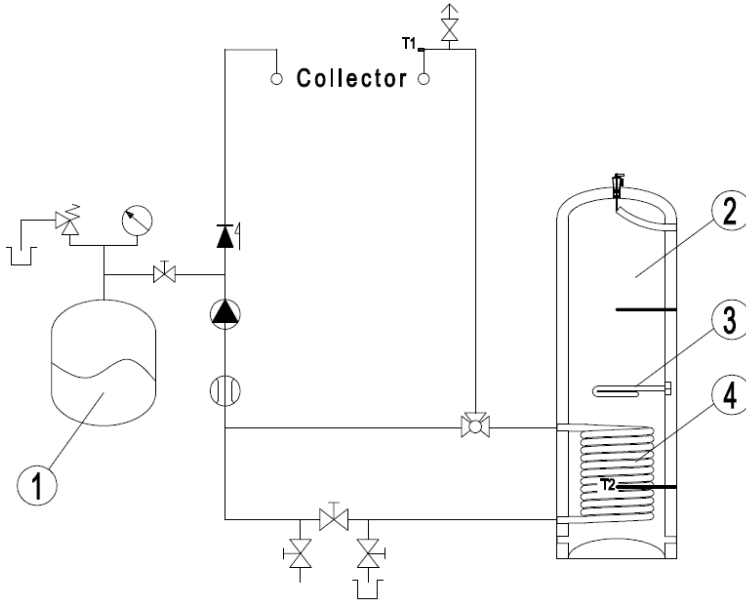

- ① Expansion Vessel
- ② Storage Water Tank
- ③ Element
- ④ Coil



7.2 Double Coils System

Double coils in the storage water tank, below coil acts as heat exchanger to get energy from the solar collectors to heat water, upper coil acts as heat exchanger from other normal heating solutions like Gas/Oil boiler etc.

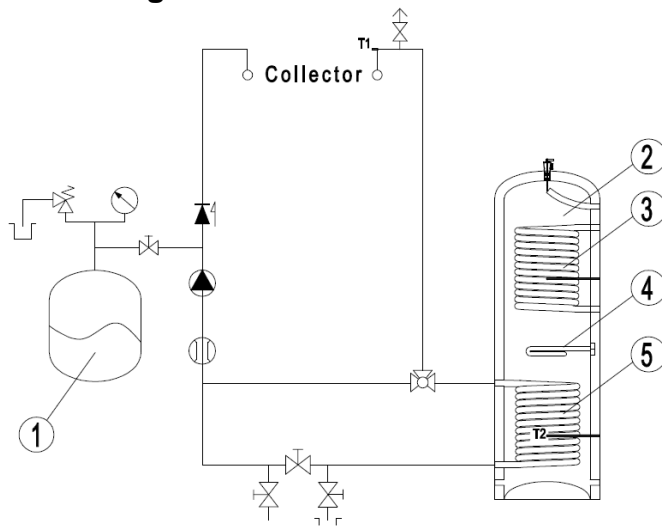

- ① Expansion Vessel
- ② Storage Water Tank
- ③ Upper Coil
- ④ Element
- ⑤ Lower Coil



7.3 Double Tanks System

When the consumption tank temperature reached the setting temperature, the motor valve will switch on to save the extra energy in the storage water tank.

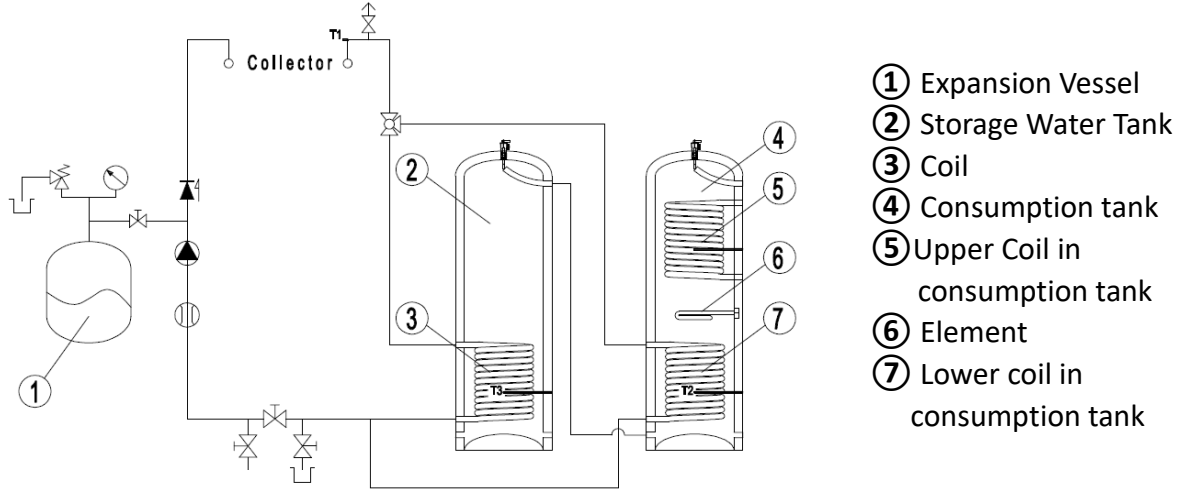

- ① Expansion Vessel
- ② Storage Water Tank
- ③ Coil
- ④ Consumption tank
- ⑤ Upper Coil in consumption tank
- ⑥ Element
- ⑦ Lower coil in consumption tank



7.4 Multi-function Combined System

It achieves consumption water, heating and swimming pool heating in one system.

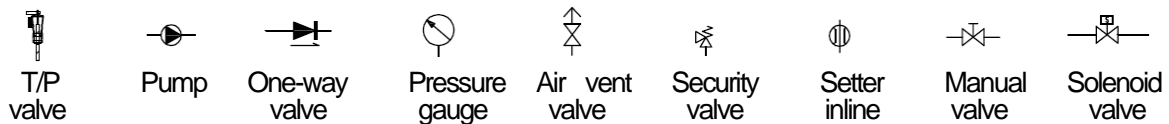
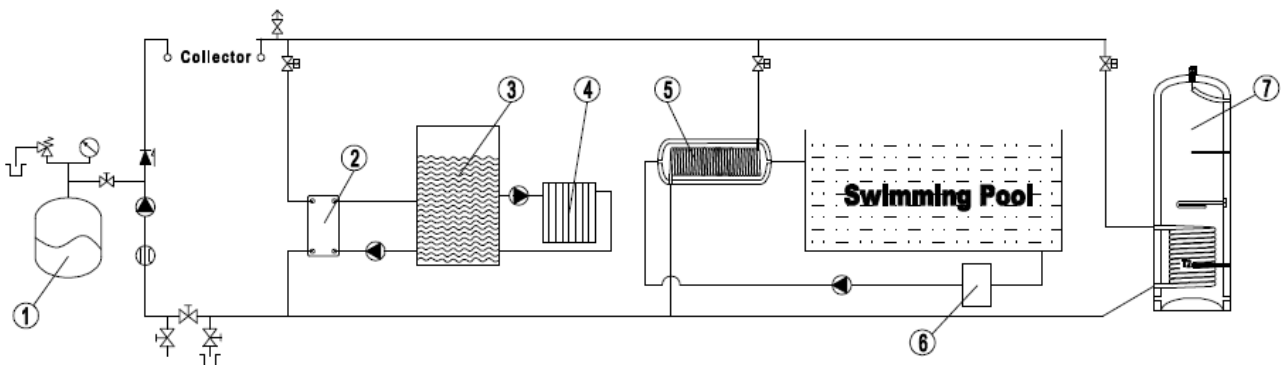

- ① Expansion Vessel
- ② Plate Heat Exchanger
- ③ Storage Water Tank
- ④ Heating Parts
- ⑤ Swimming Pool Heat Exchanger
- ⑥ Filter
- ⑦ Consumption Water Tank