USERS'MANUAL

WIND TURBINE GENERATOR SYSTEM

(2008-10-23)

CE



Warnings:

- **Please excuse from specification alterations without notice.**
- **It is required to comply with the local law, regulation or the permission from local government before installing WTGS.**
- **Only under no wind weather should proceed with the installation, maintenance and dismantling of WTGS.**
- **The installation of wind turbine generators including mechanical and electrical equipment should be operated by professional personnel. Special attention should be paid also.**
- **Color or figuration of pictures might be varied against physical goods.**
- **Two-year warranty is offered with inverter six months since the purchasing date (natural disaster or case of force majeure should excluded from the warranty).**
- **Please do not leave the wind turbines working under the unload state (eg. Without connecting with battery bank)**
- **Please do not dismantle the inner structure of wind turbines until get any instructions from us. Any personal actions without our hints to dismantle should be excluded from the rights of warranty.**

Distinguished end users,

What we offer to you are wind turbine generators that are with the advantages of easy installation, stable performance and strong service durability. These WTGS have been sold to more than sixty countries with the



total sales volume 40,000 sets.

Engaged in manufacturing wind turbine generators since 1996 , we target at developing and selling wind turbines for civil use and small-scale industry. Our products have received wide welcome from both home and abroad customers. Based on the appliance of excellent materials such as Nd-Fe-B, aluminum alloy, carbon fiber etc. and progressive exterior design and technical level, our products have been receiving wide welcome from customers home and abroad.

Please indulge yourself in the infinite convenience that brought to you by utilizing wind power. If you have any questions, please refer to this manual or consult the distributors.

Contents

Model & specification table	-----	5
Wind turbine generator constituent diagram	-----	6
Wind turbine generator installation	-----	8
Battery configuration specification	-----	12
Electrical wiring	-----	13
Maintenance	-----	16
How to disconnect wind turbine generator system	-----	17
FAQS	-----	18
Appendix: Inner connection for 3KW-20KW	-----	19



1. Models & specification table

The manual is applied to the following wind turbine generators:

Model	FD2.1-200	FD2.5-300	FD2.7-500	FD3.0-1000	FD3.6-2000
Rated power (W)	200	300	500	1000	2000
Rated voltage (V)	24	24	24	48	120
Rotor diameter (M)	2.2	2.5	2.5	2.7	3.2
Start-up wind speed (m/s)	3	2.5	2	2	2
Rated wind speed (m/s)	6	7	8	9	9
Security wind speed (m/s)	35	35	35	35	35
Rated rotating speed (r/m)	450	400	400	400	400
Blade material	fiber glass	fiber glass	fiber glass	fiber glass	fiber glass
Blade No.	3	3	3	3	3
Suggested battery capacity	12V100AH*2	12V150AH*2	12V200AH*2	12V200AH*4	12V200AH*10

Model	FD4.0-3000	FD6.4-5000	FD8.0-10000	FD12.0-20000
Rated power(W)	3000	5000	10000	20000



Rated voltage(V)	240	240	240	360
Rotor diameter(M)	4.5	6.4	8.0	10.0
Start-up wind speed(m/s)	2	2	2	2
Rated wind speed (m/s)	10	10	10	12
Security wind Speed (m/s)	45	45	25	45
Rated rotating speed (r/m)	220	200	180	90
Blade material	Fiber glass	Fiber glass	Fiber glass	Fiber glass
Blade No.	3	3	3	3
Suggested battery capacity	12V200AH*20	12V300AH*20	12V400AH*20	12V600AH*30



2. Wind turbine generator constituent diagram

2.1 Constituent diagram for wind turbine 2KW and below:

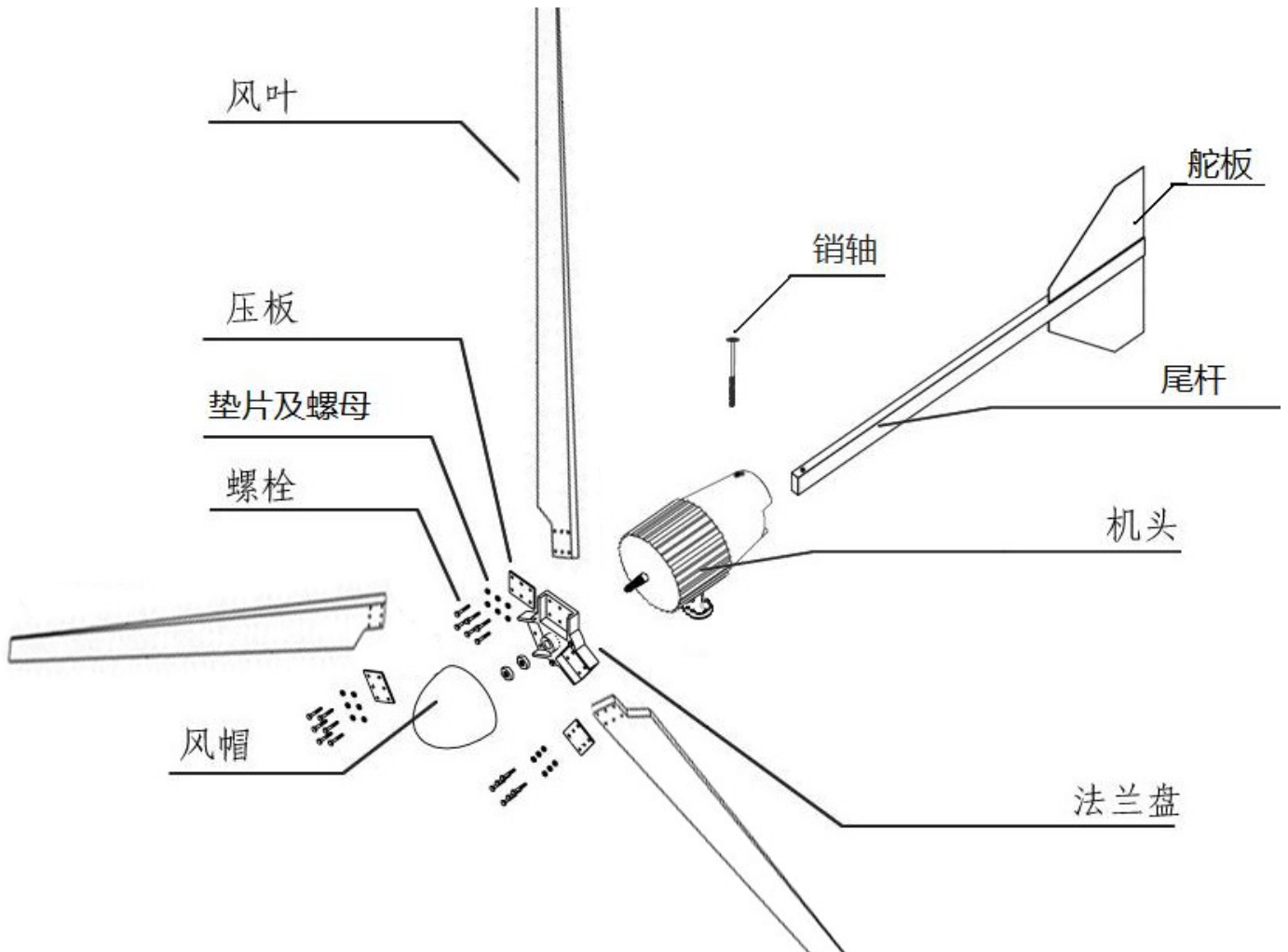

Note: The actual packing contents are not represented by the above diagram. Please refer to the packing list for the contents you have ordered.



2.2 Constituent diagram for wind turbine 3KW and above models:

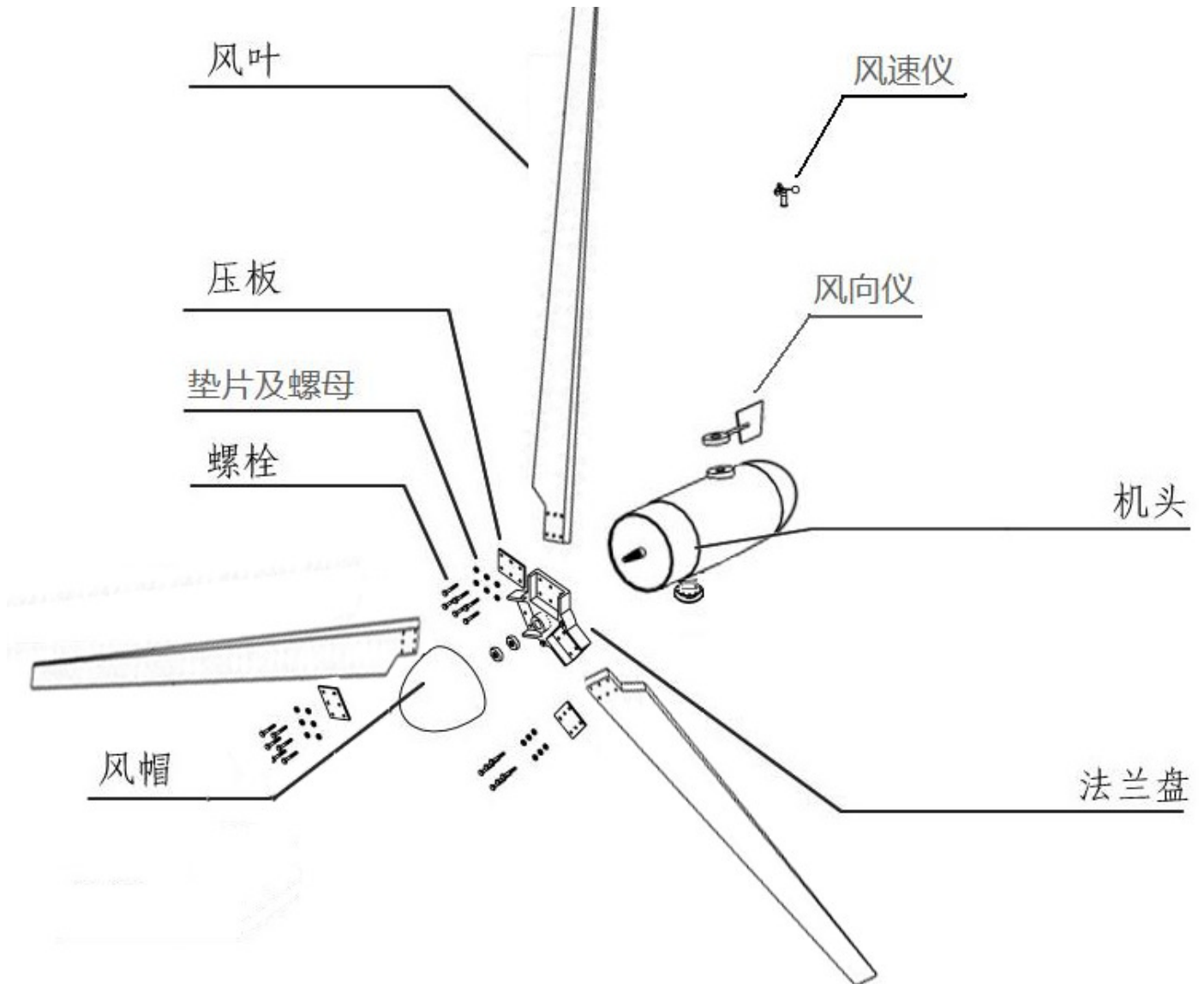

Note: The actual packing contents are not represented by the above diagram. Please refer to the packing list for the contents you have ordered.



3. Wind turbine generator installation

3.1 Tower assembly

Firstly, choose installation yard.

Wind turbine generator should be installed as high as possible to a certain extent to be far away from the obstacles in order to obtain relatively strong wind speed. Meanwhile, the soil quality of installing site should be taken into consideration. Please avoid installing wind turbine generator systems on soft sands, uneven ground or areas where the ground can be easily influenced by the climates. The distance between the battery bank and the site of installing wind turbine generator should be also taken into consideration. The shorter the distance is, the shorter the transmitting cables will be involved. Thus, there will be less power that will be wasted during the process of transmission. If the distance is longer, we do recommend you having much thicker standard cables in order to prevent any power waste.

Please refer to the tower users' manual for tower assembly.

After tower assembling, please position the upper section of tower on the stand (please refer to the following pic.). The height for the tower is 1m to 1.5m for the sake of installing turbines easily.

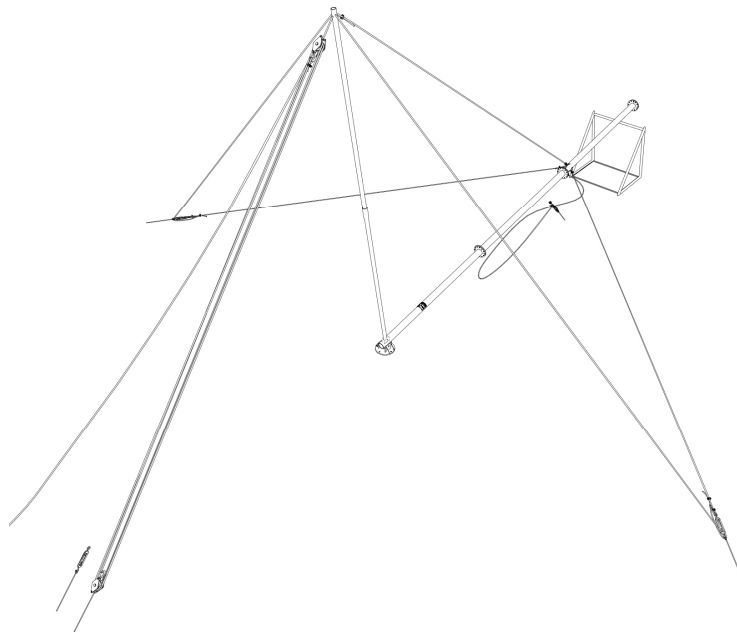

3.2 Procedures to assemble the wind turbine generator.

3.2.1 2KW & model below 2KW

- (1) To elicit the generator cables with cables from the tower bottom to the tower end by using the thin steel wires.
- (2) Hang up the wind generator by crane or chain block together with triple-angle stand. Make sure the generator axis face above and adjust the generator to make it near to the upper flange of tower upper section.
- (3) connect the cables to the three output wires from the generator (three-phase wires, without identifying positive and negative electrodes).
- (4) Connect the generator and upper flange for tower by the bolts and screw tightly;
- (5) Install the tail vane onto the end of the tail rod on the ground, and then install the tail rod with tail vane onto the generator. Insert the axis pin and screw the bolts (**Attention:** put on the taper liner).

✘Notes: The tail rods for 2KW & 2KW below models are designed to have the distortion at the end,
please do not revise it.

3.2.2 3KW、5KW、10KW、20KW



The cables have been connected with generator before leaving SWG.

- (1) Hang up the wind generator by crane or chain block together with triple-angle stand. Make sure the generator axis face above and adjust the generator to make it near to the upper flange of tower upper section.
- (2) Elicit the following cables from the tower bottom to the tower end by using the thin steel wires, the yawing cable (2 cores), signal cable (8 cores including anti-twist, temperature, wind direction, and wind speed), communication cable (3 cores), braking cable (2 cores);
- (3) Connect the generator and upper flange for tower by the bolts and screw tightly;
- (4) Open the board at the end of the generator housing and position the four - core aviation plug for anemoscope and dogvane on the hole on the generator, and then inserted into the four-core plug on connection line. Screw the waterproof connector into the hole and then screw tightly the four bolts. Please refer to the following picture;

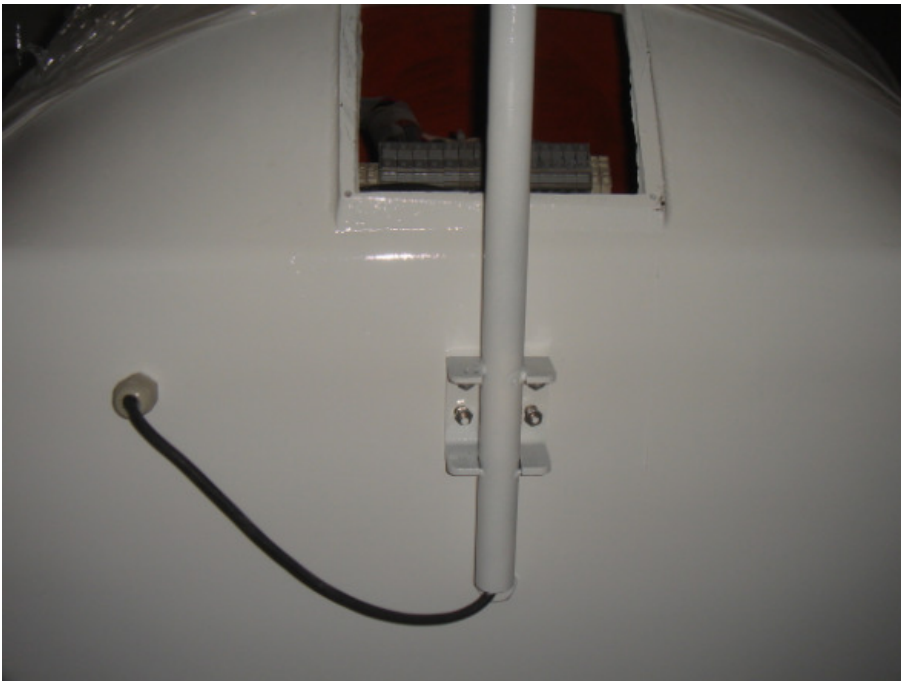

- (5) Cover the board.

✘ Provided that the users connect the wire on their own, please refer to appendix.



3.3 Blade installation

- (1) Position the blade hub to the generator axis (blade hub for 3KW & 3KW has already been installed on the generator). Special attention should be paid to the flat key to be aimed at the pit on hub.
- (2) Blade installation. Make note that the concave face of blades is towards wind. Cover the press plate and screw the bolts. Special attention should be paid to the blade balance when install the blades. First, do not screw the bolts deady, adjust the blades to make sure the equal distance between the blade tips and then screw the bolts deady (Please refer to the following pic.)

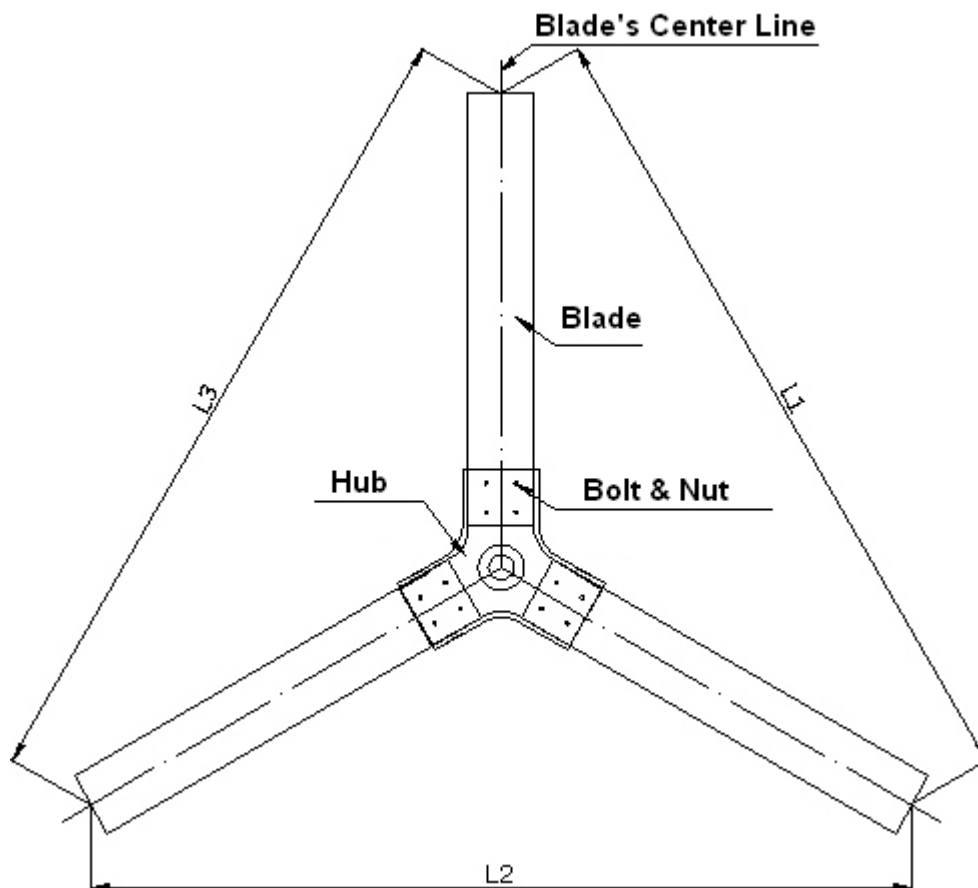

Make sure $L1=L2=L3$ (allowed difference: $\pm 5\text{mm}$). Screw the bolts according to the following order after finishing adjustment.

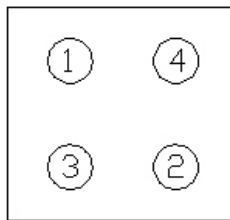

200w,300w,500w,1kw,2kw

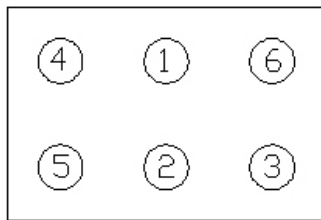

3kw,5kw,10kw

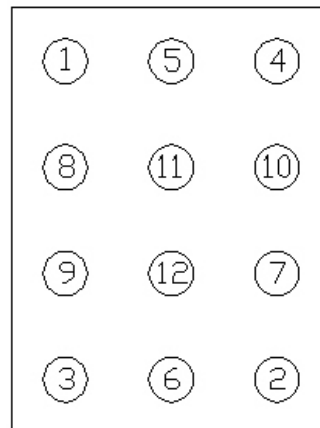

20kw

Please choose torque wrench when screw the bolts for blades, please refer to the following table for the according torque

Model	Required torque (Nm)
200W,300W	15±1
500W,1KW,2KW	30±1
3KW,5KW,10KW,20KW	50±1

✘Please following the above regulation when installing the blades. Any mistakes result in blade or hub broken due to not following the regulation will be excluded from our responsibility.

(3) Install the front nose cone

3.4 Tower erection

Please refer to the relevant tower users' manual according to the tower you have purchased



4. Battery configuration specifications

Battery bank should be put in a building where is broad and ventilated with stable temperature and dry air. According to the output voltage of the battery to decide the number of battery and choose a way to connect them in series or in parallel, and then design the shelf to place batteries, controller and inverter. To connect batteries in parallel or series, according to the requested capability and voltage, and greased all the wire heads with butter or other anti-corrosion material. To avoid the interference of electro magnet, the lead between battery and controller should be less than 3 meters.

As the suggested battery capability of all models of wind turbine generator, please refer to the model and parameter table.

The means of linking battery in series: Connect the anode of one battery to the cathode of the other in consecutive. The graph as follow (the red position is the anode of the battery, and the blue position is the cathode of battery)



The means of linking battery in parallel: connect the anode of one battery to the anode of the other, and the cathode of one battery to the cathode of the other. The graph as follow (the red position is the anode of battery, and the blue position is the cathode of battery)



※As the notices and instructions of battery, please refer to the battery manual.



5. Electrical wiring solutions

5.1 Off-grid solution (Please refer to the following diagram)

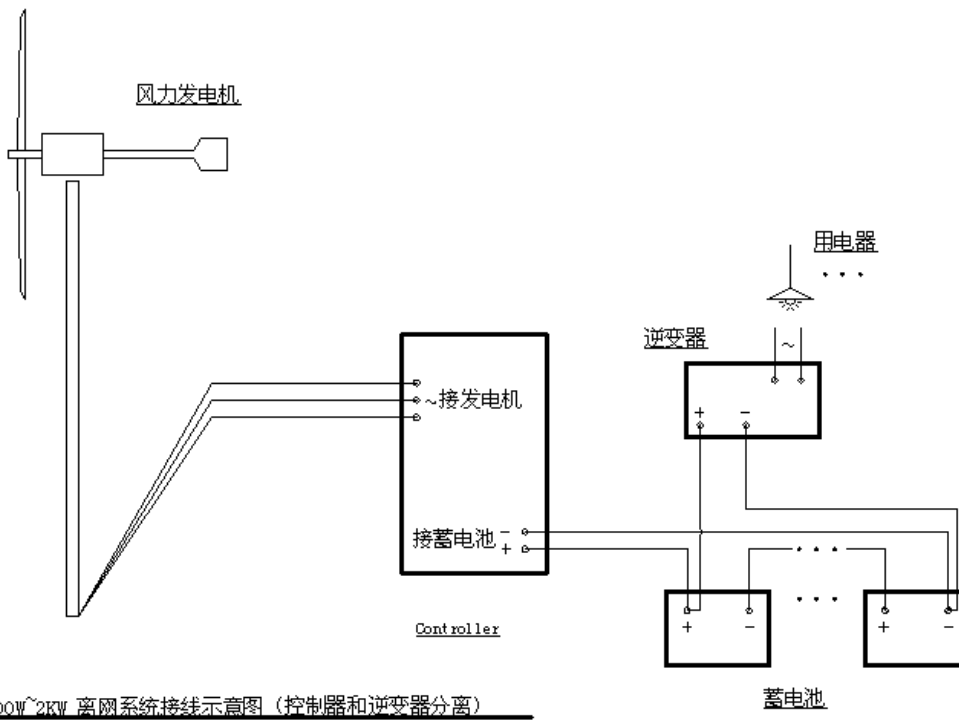
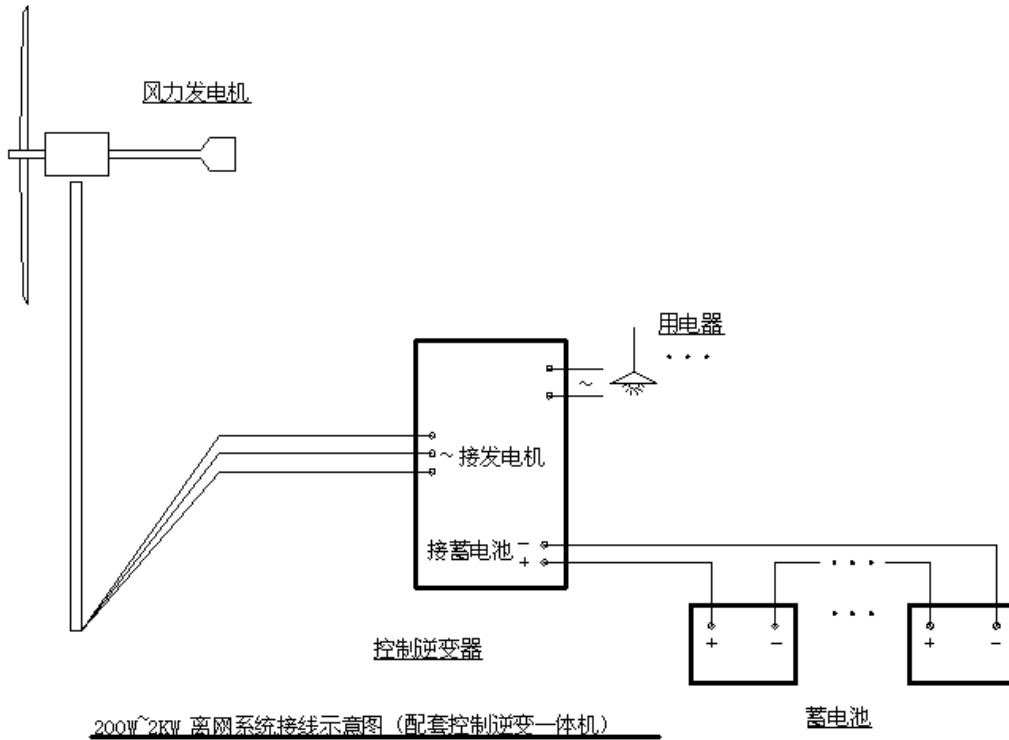

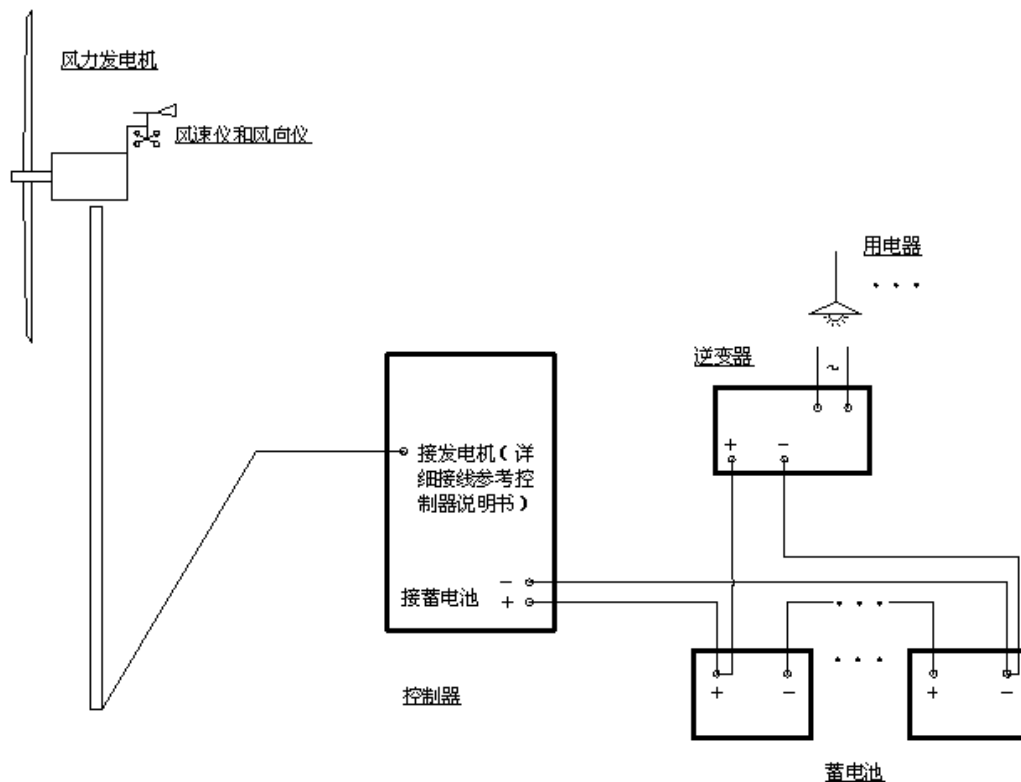

3KW~20KW 离网系统接线示意图

Make sure that the voltages among the wind turbine output, battery bank and inverter input should be the same. Please do not mistakenly connect the positive cathode and the negative cathode, which might burn down the generator, batteries or inverter.

5.1.1 Connection procedure

- (1) (3KW & 3kw above models) connect the following cables to the relevant terminals of controller: the yawing cable (2 cores), signal cable (8 cores including anti-twist, temperature, wind direction, and wind speed), communication cable (3 cores), braking cable (2 cores);
- (2) Connect negative cathode of the DC output on controller with the negative cathode of battery;
- (3) Connect positive cathode of the DC output on controller with the positive cathode of battery;
- (4) Connect the three wires from generator to the terminals for generator on controller (not need to pay attention to the wire color. Three-phase output, not need to differentiate the positive and negative cathode);



- (5) Switch off the inverter, and then connect the negative cathode of battery bank to the inverter's;
 - (6) Connect the positive cathode to the inverter's;
 - (7) Turn on the inverter, and then connect the household appliance to the inverter. Switch off the inverter when you finish the usage;
- ✘If there is any requirement for the DC, you can connect directly to the battery or connect to the DC output terminal on controller (not all the models have the DC output terminals).

5.2 On-grid solution (Please refer to the following diagram)

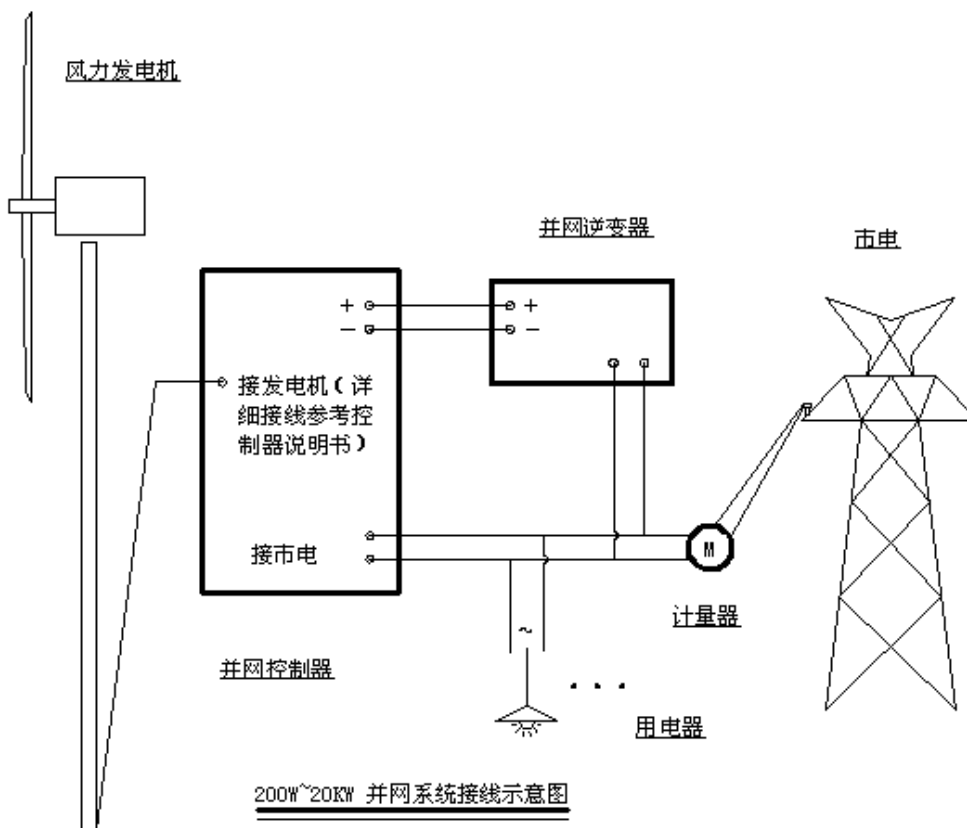

All models of WTGS can be applied into on-grid purpose. However, it is required to be accorded with the local government permission. And on-grid inverter should be purchased by the users themselves.

Please refer to controller users' manual for the detailed connection.



6.Maintenance

To maintain the whole system smooth operation, we need to carry on the inspection and maintenance regularly for wind-driven generator, because its condition maybe extremely bad or even possible to meet all kinds of complex weather condition.

6.1 Notes:

(1) To check the tower cable whether too loose or too tight and do adjustment in time, especially at the initial stage of installation or after suffering the heavy wind.

(2) We should pay attention to the maintenance electrolyte altitude of the batteries, if reduced, increase promptly. For the concrete method, please refer to the users' manual of the batteries.

(3) Before suffering the storm or execrable weather, we do suggest to take the tower down in order to avoid the unpredictable loss.

(4) In order to prevent any unpredictable loss, we do recommend laying down the tower before the storm or any adverse weathere.

6.2 Maintenance schedule (Please refer to the following table)

No.	Item	After Winter	After Storm	Per year	Per five years	Per ten years
1	Check blades: look for cracks or abnormal bends. If you locate any damage caused by storms or weather, replace the blades as using damaged or unbalanced blades will compromise the efficiency and lifetime of the windmill.	√	√		√	



2	Grease ball bearings.	√		√
3	If it is guyed cable tower, check for cable tension and adjust as needed.	√	√	√
4	Check to see if nuts and bolts have remained tight on mill and tower.		√	√
5	Check electric power cables for corrosion and damage. If you detect any abnormal corrosion, replace cables.	√		√
6	Check state of the rotor for abnormal tear and wear. If needed, replace or retool to ensure proper functioning.			√
7	Replace gaskets.			√
8	Paint touch up areas with weather damage.			√
9	Replace blades with new set of blades.			√
10	Replace electric power cables going from windmill to converter/controller.			√



7.How to disconnect wind turbine generator system

(1) Only under no wind weather can proceed with the disconnection of wind turbine generator system. And turn off the inverter switch.

(2)<3KW & models above 3KW> Wind turbine 3KW and above

Firstly, shut down the wind turbine generator. We could set the switch as manual on the operation board, and then press the button of clockwise or reversal, until the blades face to the wind in 90 degrees, to realize the generator shutdown.

When the blades stop rotate, disconnect the link of the three output wire with the controller, then make a short circuit to avoid the blades to continue to rotate.

Press again the clockwise or reversal button to make sure the blades backward to the direction of the earth to prevent from the damage of blades when put down the generator.



Disconnect the link of the signal wires, dogvane and anemoscope with the controller.

(3)<2KW & models below 2KW> disconnect the link between the three output cables and controller, and then make a short circuit of the three cables.

(4) Disconnect the link between battery and controller.

(5) Disconnect the link between inverter and battery.

8.FAQS

1. Why doesn't the electric equipment work normally after it is connected to the system?

Please check the left energy of batteries, for the equipment can't work smoothly if the energy is not enough. But if the energy is enough, make sure whether the wiring between batteries and inverter is correct.

2.Why can't the batteries be charged?

Check whether the blades are turning or not, because the generator has no output at too high or too low wind speed. But if the blades are running normally, please disconnect the cables of batteries and inverter at first, then check the output of the generator with a voltage meter. If the output is in gear, please examine the batteries are ok or not, if the output is zero, please check the cable of the generator.

3.Why can't the blades turn at a normal wind speed?

If the output wire of the generator is connected short, the blades don't work, please disconnect the cables of



batteries and inverter, and then check the generator's cable.

4. Whether can the using time of electro-equipment be prolonged through enhancing the capacity of the batteries?

If the suggested batteries capacity is added, it will cause the batteries to be a situation of lacking energy in a long time, which will influence the life-span of batteries and lead waste.

5. The generator of 3KW and above can't automatic follow the wind direction.

- 1) Check the anemoscope is broken or not. Method: observe the controller to make sure whether it can show the wind speed or not.
- 2) Check the dogvane is broken or not. Method: pull out the plug of the dogvane from the controller, and you will see three lines with the mark of 1,2,3. Measure the resistance of 1 and 2 with the multimeter, it should be about 1000Ω. And then measure the resistance of 1 and 3, 2 and 3 respectively. The both of figures should be equal to the figure of 1 and 2.
- 3) If the above checked result is normal, then ensure that the controller board is set on the automatic situation. Otherwise, it can't automatic follow the wind direction. If like this, it still can't follow the wind direction, maybe because the wind speed is too low. Only when the wind speed is more than 3m/s and keeps the speed more than 30 seconds, can it follow the wind direction and change the angle of facing wind.



Appendix: Inner connection for 3KW-20KW

(1) Open the square cover at the backside of generator

(2) All the cables have been elicited from generator and then they will go through the pulley to the connection line.

Connect the generator and tower by bolts and tight the bolts. After adjusting the length of cables and fixed it with clippers as follow;

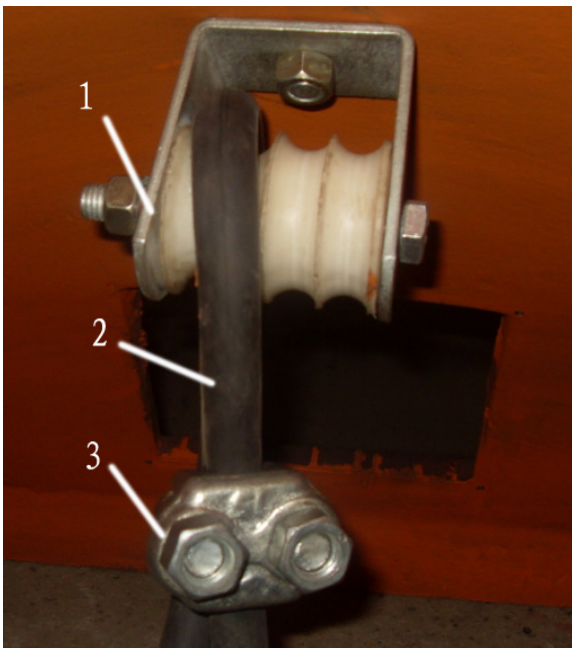

1- Pulley

2- Cable

3- Clipper

Remarks: Not all the cables have been shown on the left pic.

(3) Please refer to the following connection line for the generator. Please match the cable with the No. shown on connection line accordingly.

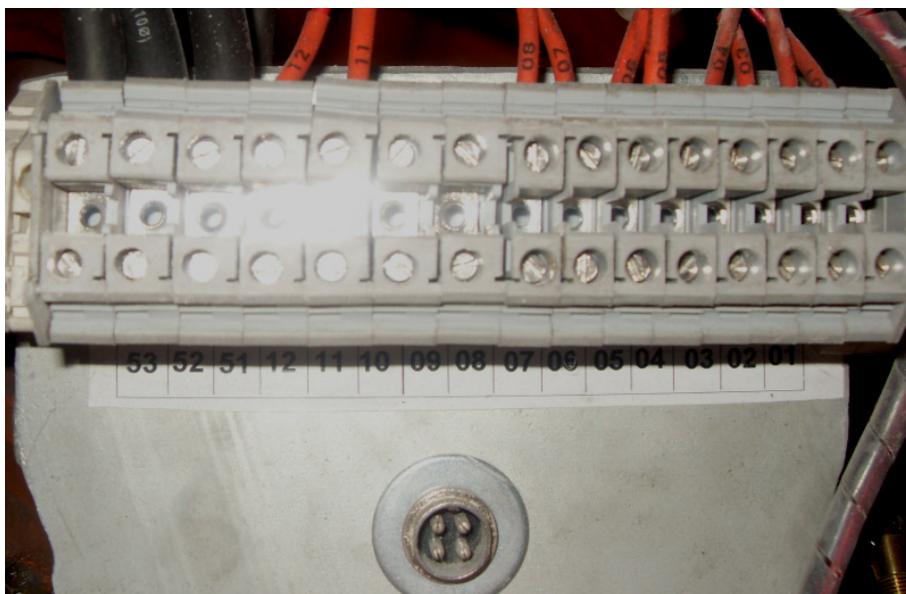

Terminal definition & cable color:

- 01- 5V , red
- 02- 0V , white
- 03- Wind speed , green
- 04- Wind direction , yellow
- 05- Anti-twist , black
- 06- Anti-twist , blue
- 07- temperature , brown
- 08- temperature , gray
- 09- brake , red
- 10- brake , black
- 11- yawing (+) , red
- 12- yawing (-) , black
- 51- generator , brown
- 52- generator , brown
- 53- generator , brown

(4) Cover the board after finish the connection.

神
