

BE > THINK > INNOVATE >

HEATING SYSTEMS IN DOMESTIC DWELLINGS



GRUNDFOS 

Welcome to your personal guide for circulator pumps for domestic dwellings

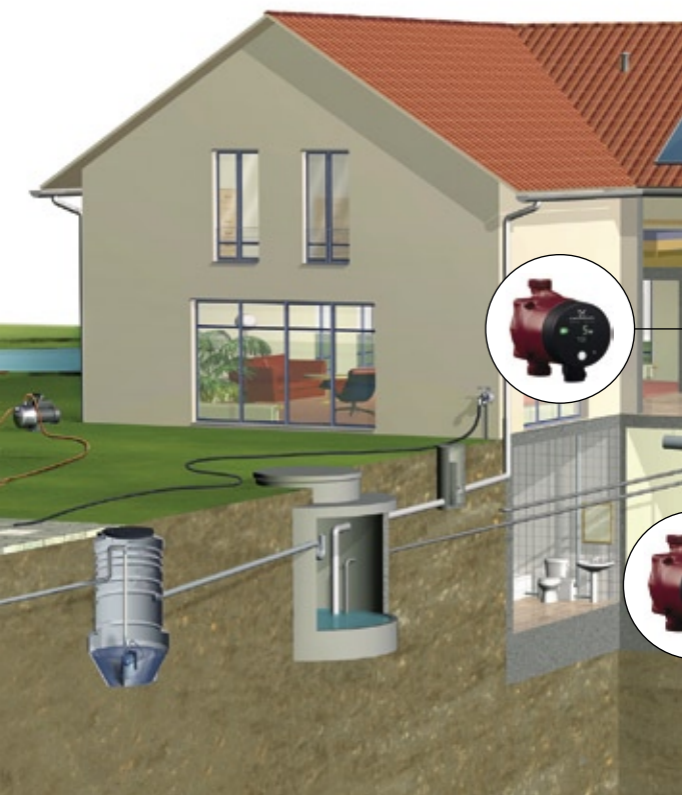

The guide contains the following elements:

APPLICATIONS

PUMP SELECTION

ACCESSORIES

THEORY

TROUBLE SHOOTING

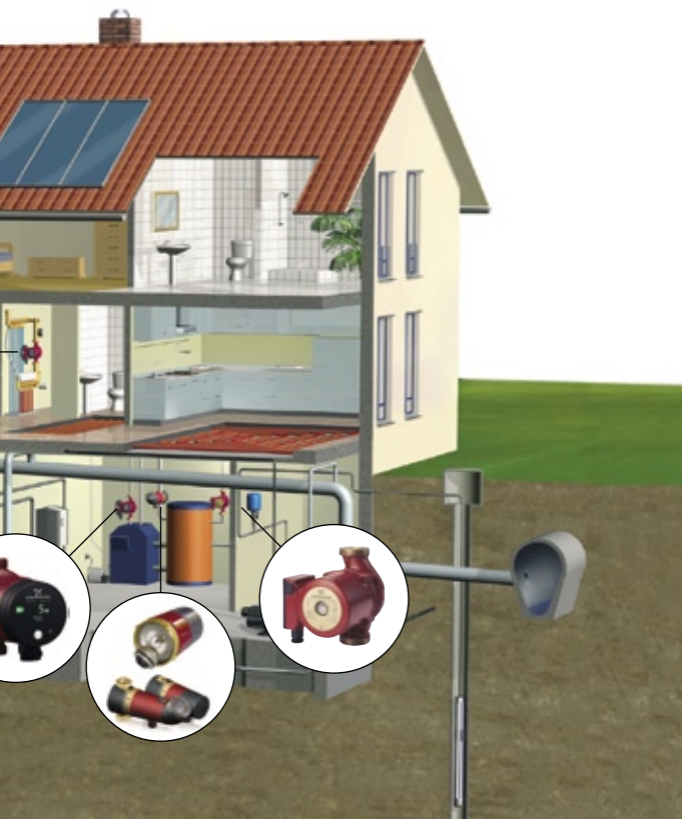



APPLICATIONS

Circulator pumps and pump systems for domestic dwellings.....	6
Application overview	7
System construction One-pipe system	8
System construction Two-pipe system	9
Under-floor heating.....	10
Under-floor heating construction.....	11
Boiler systems.....	12
Alternative fuel.....	13
Heat exchangers	14
Domestic hot water application	15
Heating circulators.....	16
Circulation of domestic secondary hot water	17
HWS (bronze) Pump Selection Chart.....	18
Solar panels.....	20
Cooling and air conditioning systems.....	21
Geothermal heating / cooling.....	22
Heat from the ground.....	23
Heat from ground water.....	24
Heat from the air.....	25

PUMP SELECTION

The Energy Project.....	28
It always pays to read the label	29
Grundfos ALPHA2 Circulator	31
Grundfos UPS Circulator	32
Grundfos MAGNA.....	33
Grundfos COMFORT.....	34
Grundfos UP – N/B Circulator.....	35
Grundfos SOLAR.....	36
Grundfos TP.....	37
Grundfos TPE.....	38
Grundfos Conlift.....	39
Choice of Standard Grundfos Low Energy Spare Head.....	40

ACCESSORIES

Grundfos GT tanks for hot water.....	42
Sizing of heating tanks.....	43

THEORY

The basic principles.....	46
Heat loss.....	47
Flow calculation	49
Flow variation.....	51
Load profile of a heating system	52
Pressure relations in a heating system.....	53
System pressure.....	54
Open expansion systems.....	55
Pressurised expansion systems.....	56
Head.....	58
Pressure loss.....	60
Pump curves/system characteristics	61
Pressure loss.....	62
Balancing a heating system.....	63
Static pressure.....	64
Pre pressure (P_0).....	65

TROUBLE SHOOTING

Heating circulators.....	68
Useful pump tips.....	69
Domestic secondary hot water return	71
Useful pump tips.....	72
Find detailed information via the UK website.....	78

CONTACT

Addresses.....	87
----------------	----

Circulator pumps and pump systems for domestic dwellings



1 Heating

2 Hot water

3 Hot water recirculation

4 Solar system

Application overview

Application	Pump type					
	ALPHA2	UPS	Spare parts*	Comfort	UP-N/B	Solar
Wall-mounted gas boilers			■			
Gas/oil boilers	■					
One-pipe system	■	□				
Two-pipe system	■	□				
Under-floor heating	■	□				
Solar system						■
Hot water recirculation				□	■	
Hot water	■			□	■	

■ = Best choice

□ = Secondary choice

* Standard Grundfos Low Energy pump heads only for Standard Grundfos circulators in wall-mounted gas boilers.

System construction One-pipe system

Horizontal distribution

Constant flow

Low differential temperature

Accurate sizing required for correct hydraulic balance

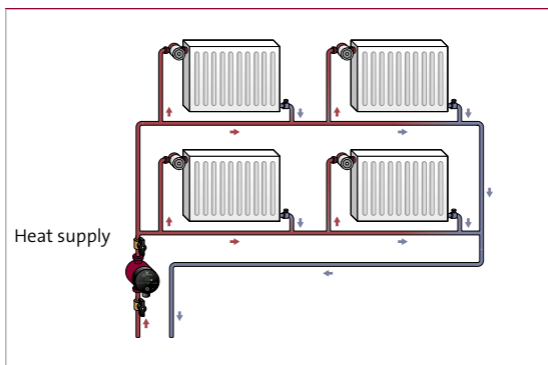

System construction

Two-pipe system

Horizontal distribution

Variable flow

High differential temperature

Accurate sizing required for correct hydraulic balance

Use either the TRV balancing ring or a lock shield valve

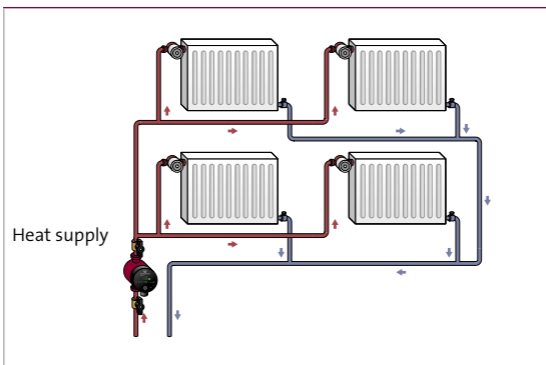

Under-floor heating

In an under-floor heating system, the heat will be transferred from pipes to the floor construction. Under-floor heating can be combined with traditional radiator heating.

A big difference between a radiator and an under-floor heating system is the operating temperature. A radiator system can be dimensioned for a flow temperature of up to 82°C and a differential temperature of up to 20°C , whereas in an under-floor heating system the flow temperature must never exceed 40°C and the differential temperature is never more than $5\text{--}8^{\circ}\text{C}$. An under-floor heating system always needs a mixing loop to get the right flow temperature.

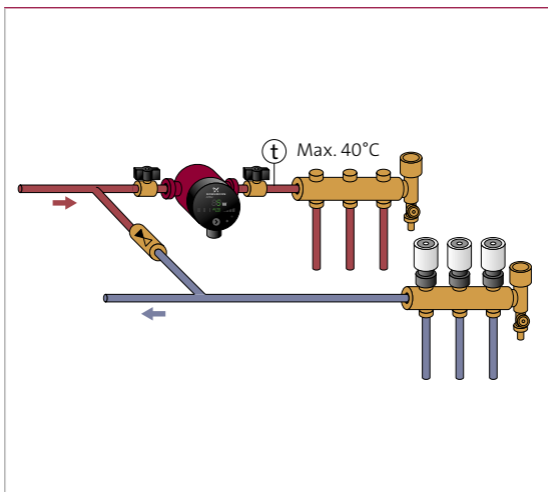

Under-floor heating construction

An under-floor heating system can be designed in many different ways. Always follow the manufacturer's guidelines. Each room should have its own control, and all pipe circles must be balanced to have the same pressure loss. The pressure loss in the longest pipe circle (never longer than 120 m) is used for dimensioning the pump.

The high-pressure loss and the low differential temperature in an under-floor heating system call for a larger pump than a traditional radiator system for the same size building. The flow will be variable and it is recommended to use a speed-controlled pump such as a Grundfos ALPHA2.

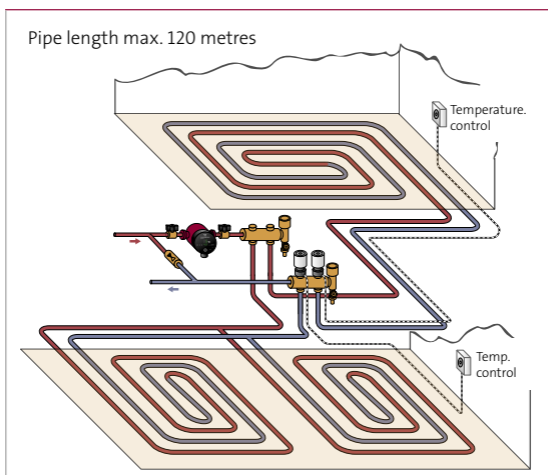

Boiler systems

There are two types of boiler systems:

- wall-mounted gas boilers
- floor standing gas/oil boilers

Wall-mounted gas boiler

- Often supplied with a special, integrated pump, developed in close cooperation with the boiler manufacturer.
- Some wall-mounted gas boilers are delivered without an integrated pump.
- If supplied with a standard Grundfos circulator, Grundfos Low Energy pump heads are available for replacement.

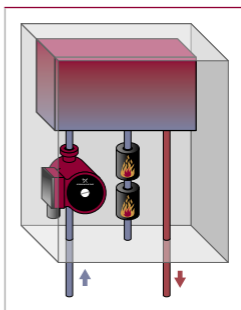

Floor standing gas/oil boilers

- Many variants are available; the pump may be placed inside or outside the cabinet.
- If you use the Night Set Back function, remember to place the pump at the outlet.

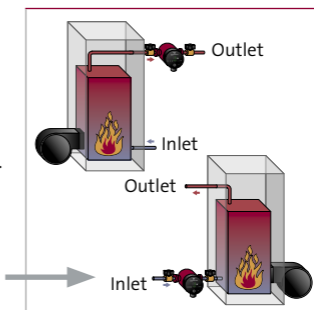

Alternative fuel

- May use a variety of fuels such as wood, straw, or wood pellets. Often operate at higher temperatures than gas/oil boilers.
- Different local restrictions may apply, and the boiler manufacturer may specify limitations concerning minimum flow through the boiler.
- Minimum flow can be ensured by means of a boiler shunt pump. Temperature differences between the top and bottom of the boiler will also be minimised. Pump inlet pressure must be checked in accordance with local restrictions on open expansion systems.
- Grundfos recommend installing a TP in-line pump for alternative fuel boilers.

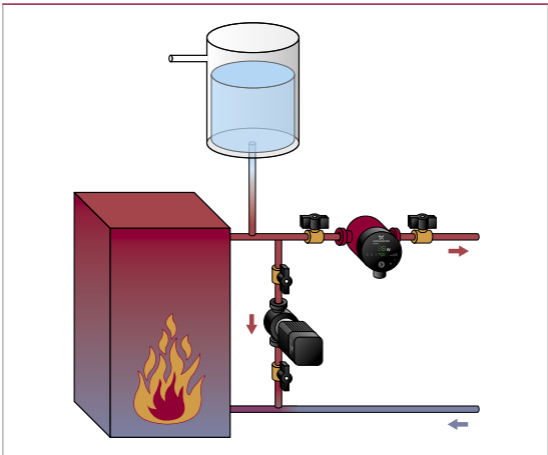

Heat exchangers

- Commonly used for the production of hot water in domestic buildings and district heating systems. The heat exchanger transfers energy from one media to another, causing a small drop in temperature from the primary to the secondary side.
- The pump on the secondary side is normally placed on the return pipe. A control valve on the primary return pipe, controls secondary side flow temperature.
- Please note: If you use the Night Set Back function, remember to place the pump at the outlet.

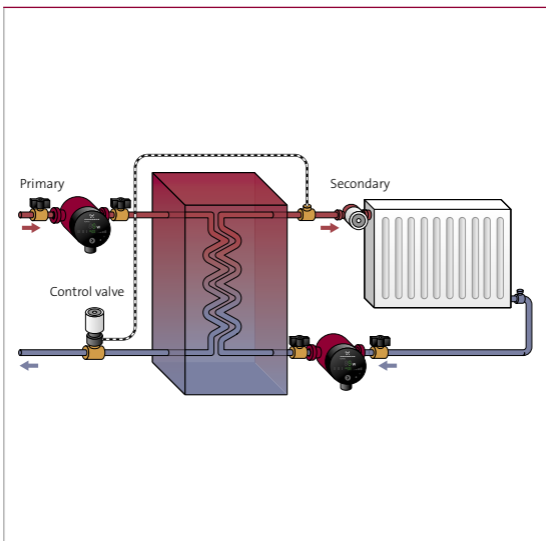

Domestic hot water application

- A secondary return system ensures instant hot water at any tap in the system and eliminates dead legs. Waste is minimised at the same time.

Please note:

- Flow in the return pipe is low; a small pump is therefore required.
- If the pump is too large, and flow is excessive, the high velocity in the pipe will produce a noisy system.

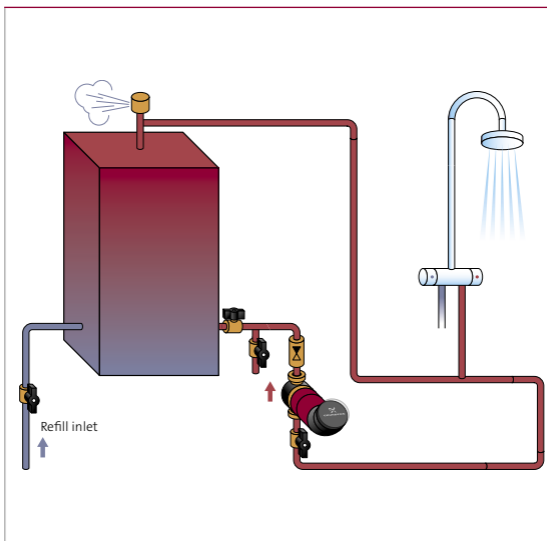

Heating circulators

Selecting the right pump

When replacing an existing pump, we recommend asking whether changes have been made to the house since the original pump was installed. Remodelling or improvements to the heating system can include:

- New insulated glass unit
- Additional insulation
- New thermostatic valves.

Most old pumps are larger than necessary. They can be replaced with smaller, speed-controlled Grundfos pumps. A speed-controlled pump will adapt to the new situation, minimise the risk of noise, and at the same time save energy.

House (m ²)	Radiator system Δt 20°C	Pump type Radiator system	Floor heating Δt 5°C	Pump type Floor heating	
				First choice	Second choice
80-120	0.4	ALPHA2 15-50	1.5	ALPHA2 15-50	UPS 15-50
120-160	0.5	ALPHA2 15-50	2.0	ALPHA2 15-60	UPS 15-60
160-200	0.6	ALPHA2 15-50	2.5	ALPHA2 15-60	UPS 15-60
200-240	0.7	ALPHA2 15-50	3.0	MAGNA 25-60	
240-280	0.8	ALPHA2 15-60	3.5	MAGNA 25-100	

For additional information, see Theory/Flow Calculation.

Circulation of domestic secondary hot water

Experience shows that most circulators are too large. You should therefore calculate the system requirements every time you need to replace an old pump.

You can do so by following the rules of thumb listed below.

Conditions:

For insulated pipes placed in heated rooms, calculate with a loss of 10 W/m.

For insulated pipes placed in unheated rooms, calculate with a loss of 20 W/m.

The pressure loss of the non-return valve is set to 10 kPa.

Flow and return temperature differential = 5°C

Max. speed in the pipes is 1.0 m/s, but only 0.5 m/s in copper pipes to avoid noise and corrosion from turbulence in the pipes.

Formula:

$$\frac{\text{kW} \times 0.86}{\text{Flow and return temperature differential}} = \text{m}^3/\text{h}$$

Continued on next page >

Total Loop Length (m)	Return Pipe		Flow Pipe		Req'd Flow Rate (l/s)	Pump Selection	Pump Press (kPa)
	Size (mm)	Loss (Pa/m)	Size (mm)	Loss (Pa/m)			
145	15	1	22	0	0.15	UPS 15-50 B	42
225	22	3	28	1	0.23	UPS 15-50 B	38
490	28	12	35	4	0.49	UPS 15-50 B	36
750	35	28	42	10	0.75	UPS 25-55 B	47
900	42	41	54	14	0.90	UPS 25-55 B	44
1200	54	72	67	25	1.20	UPS 25-55 B	36
330	22	348	28	101	0.26	UPS 25-80 B	74
425	28	261	35	82	0.43	UPS 25-80 B	72
535	35	181	42	68	0.64	UPS 25-80 B	67
895	54	79	67	27	1.25	UPS 25-80 B	47

HWS (bronze) Pump Selection Chart

(see chart on page 18)

The calculated pipe lengths are insulated pipe with a 5 deg C return differential.

The pipe lengths above are based on a single loop, with the given pipe loss per meter length.

The selection table assumes the the flow pipe to be the next pipe size up, and the return pipe to be the same length as the flow pipe.

Multiple Loops

For multiple loops, the individual loop flow is calculated at approximately 0.1 l/s per 100m.

The total flow required is then the sum of the individual loop flows.

To calculate the index circuit resistance, an indication of pipe loss can be derived from the table on the previous page.

The total circuit resistance must not exceed the pump pressure available figure above.

Multiple loops must have regulating valves to allow flow balancing.

Solar panels

Solar panels are used to supplement the supply of domestic hot water and heating. All systems are water-based, and therefore require a circulator pump.

Installation note:

The pump must be able to handle the following conditions:

- Anti-freeze additives that may be in the water
- High water temperatures
- Large temperature fluctuations.

Grundfos recommends the following pump for this application:

- UP Solar

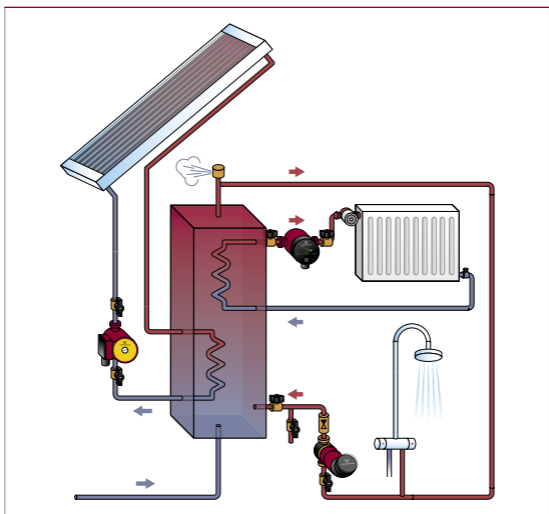

Cooling and air conditioning systems

For cooling and air conditioning systems, use standard pump types UPS and MAGNA, depending on type/size. (See product range.)

Temperature range: 25°C to +110°C

These pumps are thus suitable for circulation of both cold and hot water.

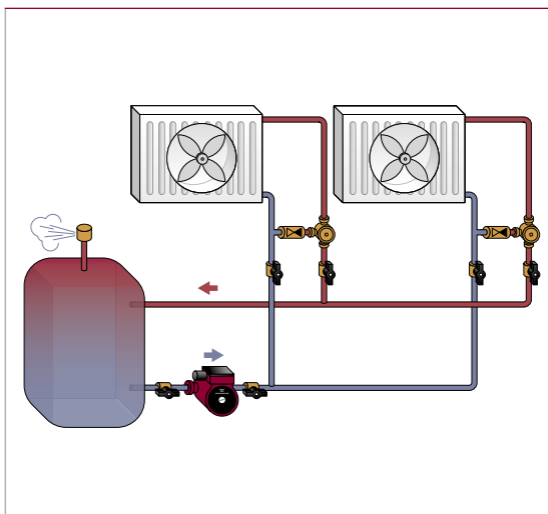

Geothermal heating / cooling

Utilising the temperature found in the ground or in the air offers additional ways to heat or cool homes. Specially constructed systems can be used for both heating and cooling, producing according to demand. In the winter, these systems move the heat from the earth into your house. In the summer, they pull the heat from your home and discharge it into the ground.

Central to the system is a circulation pump and a reversible heat pump or chiller unit. The chiller contains a condenser, an evaporator, a compressor and an expansion valve. The condenser is used for heating up the circulating water during wintertime; the evaporator is used for cooling down the same circulating water during summertime. Freon is present as a refrigerant.

Installation note:

- The circulation pump must be able to operate with ambient temperature from +6°C to +55°C.

Heat from the ground

In the heating mode (wintertime), evaporation of liquid freon is obtained by a glycol/water mixture (at about -17°C). The ground reheats the mixture before returning to the evaporator.

The freon gas is then pressurized and circulated to the condenser to provide its heat to circulating water.

In the cooling mode (summertime), the condensation of the freon gas is obtained by a glycol/water mixture. The ground cools down the mixture before returning it to the condenser.

Liquid freon is then de-pressurized and circulated to the evaporator to absorb the heat from the circulating water.

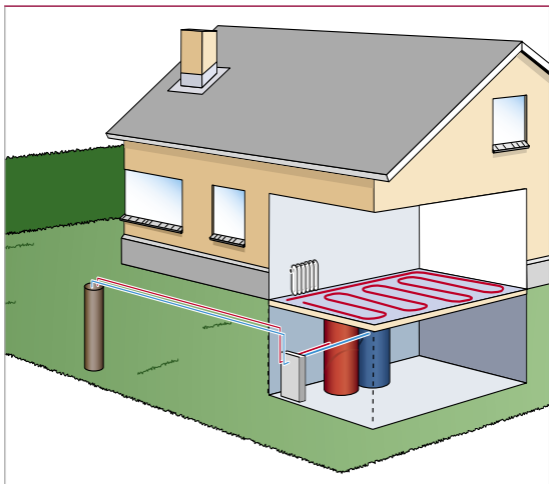

Heat from ground water

A submersible pump pumps the constant-temperature ground water into the evaporator during wintertime, and into the condenser during summertime. The cooled or warmed water is returned to the water table through dispersion.

The way of providing or absorbing the heat from the circulating water is the same as for previous system (heat from the ground).

Installation note:

Local regulations may prohibit this type of installation, due to the dispersal of the cool water. Always check with your local authorities beforehand.

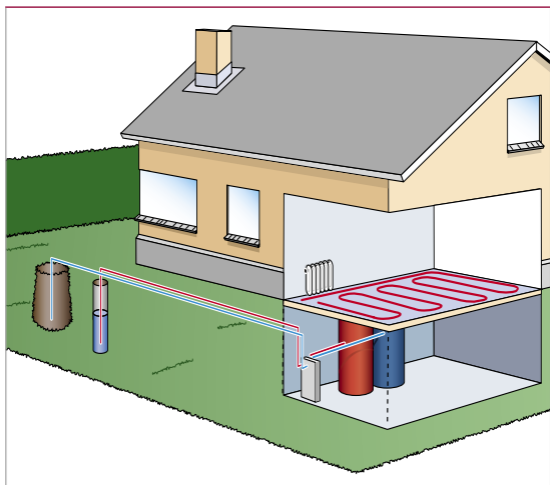

Heat from the air

Freon evaporation during wintertime and freon condensation during the summertime is obtained by outdoor air.

The way of providing or absorbing the heat from the circulating water is the same as for previous system (heat from the ground).

Installation note:

Minimum outdoor temperature is approximately 0°C . Temperatures below this will prohibit the system from working properly or efficiently.

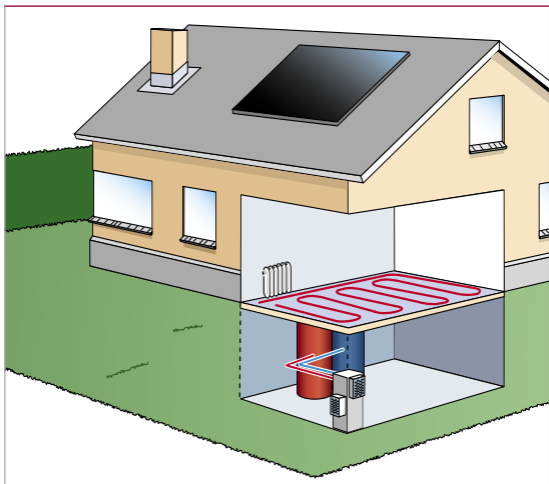

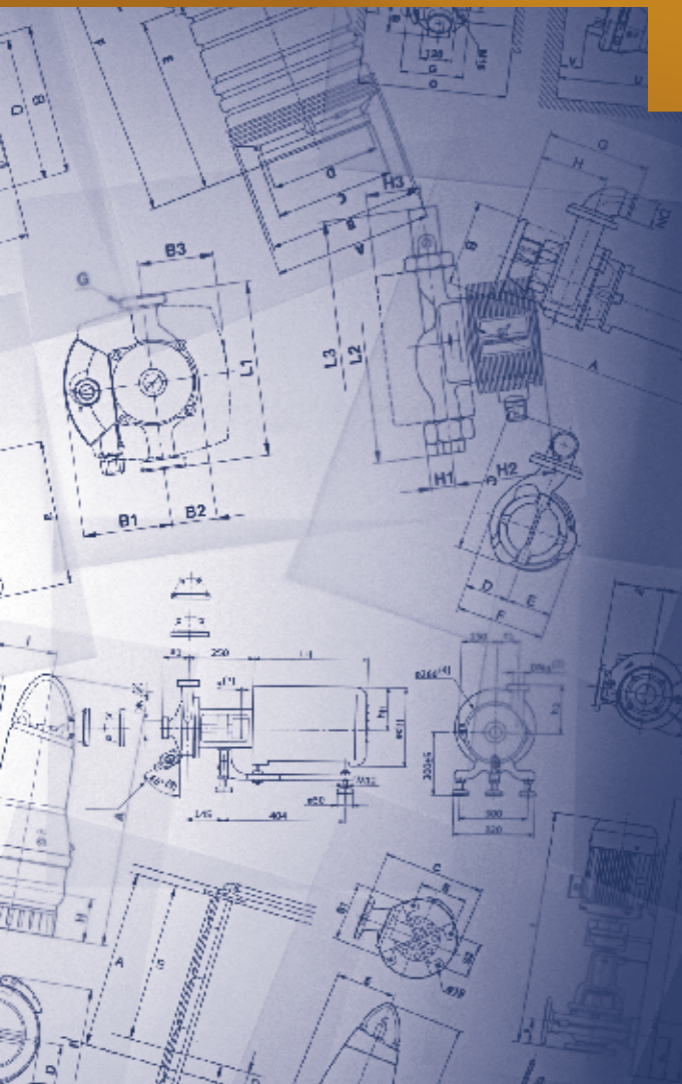

The Energy Project

When Grundfos talks about the Energy Project, it is an expression for the dedication to advise customers to choose the most energy-efficient solution.

All over the world today, we face the same challenge. In every society we need more power, but we must consume less energy to protect the environment. We need to find ways to use less energy, and energy-efficient pumps represent a major savings potential.

Finding ways to make consumers more aware of the energy they use and cutting down on that energy is now positively affecting the pump industry. Grundfos has been exploring energy-saving ideas since the early 90's – and now, more than ever, it is desirable to choose a reliable, long-lasting and energy-efficient pump.

Upgrading circulators holds a great potential for savings

Average annual energy consumption in European households in kWh

*Circulator pump



Washing machine



Refrigerator



Many customers are not aware that changing to A-rated circulators is one of the most energy-saving upgrades that you can do in a private household.

* May be slightly less in UK due to program controlled systems.

It always pays to read the label

The well-known EU energy label has guided the homeowners choice of appliances such as refrigerators and light bulbs for several years, making it easy to identify the best energy-efficiency and thus lowest electricity usage. Making the informed choice helps us all reduce the CO2 emissions.

Energy labelling for circulator pumps was introduced in Europe in 2005. An energy label rates a pump's energy efficiency from A (most efficient) to G.

To put this in perspective, the average circulator installed in European homes today has an efficiency rating of D. By switching to an A-labelled circulator the homeowner stands to use up to 80% less electricity than they would with a D-labelled pump.

Major savings from energy-efficient circulators

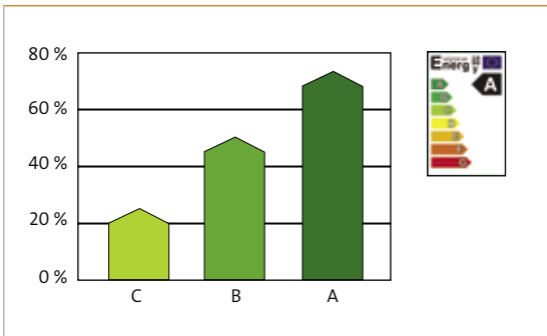

Energy savings compared to an average D/E pump C-, B- and especially A-labelled pumps give significant energy savings compared to a pump of average energy consumption.

30 PUMP SELECTION

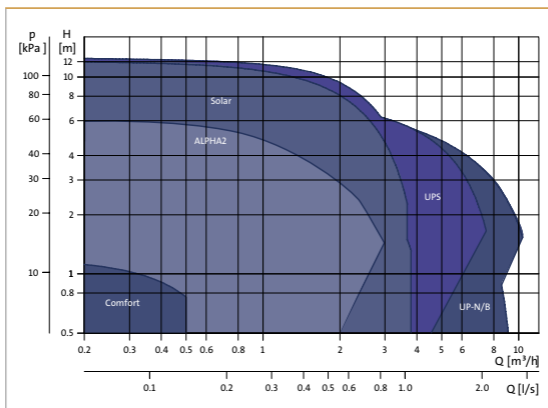

	Pump type				
	ALPHA2	UPS	Comfort	UP-N/B	Solar
Connections					
Rp ½"			x		
G 1"	x	x			x
G 1¼"		x	x	x	
G 1½"	x	x		x	x
G 2"	x	x		x	
DN 32		x		x	
DN 40		x		x	

Rp = inside thread

G = outside thread

DN = flange

Grundfos ALPHA2 Circulator

– for heating systems

- AUTOADAPT
- LED-display
- Night set-back function



Technical data

Liquid temperature:	+2°C to +110°C
Operating pressure:	Max 0.1MPa (10 bar)
Power range:	5W - 45W
Speed:	Variable and Fixed speed (1-3)
Connections:	Unions
Port to port:	130mm
Pump housing:	Cast iron
Applications	Heating

Energy label: 5m: A
 6m: A



Performance curves

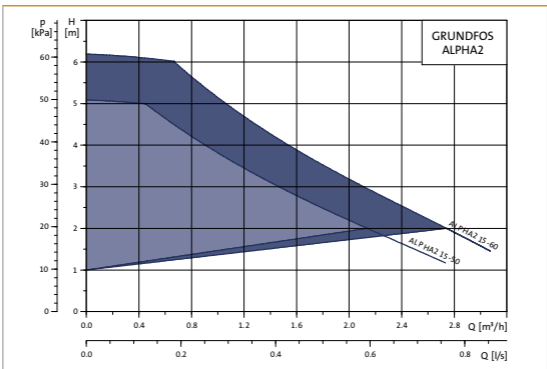

Grundfos UPS Circulator

– for heating systems



Technical data

Liquid temperature:	-25°C to +110°C
Operating pressure:	Max 0.1MPa (10 bar)
Power range:	25W to 350 W
Speed:	Fixed speed (1-3)
Connections:	Unions, flanges
Port to port:	130 to 250 mm
Pump housing:	Cast iron

Energy label:	5m: B
	6m: B
	10m: C



Performance curves

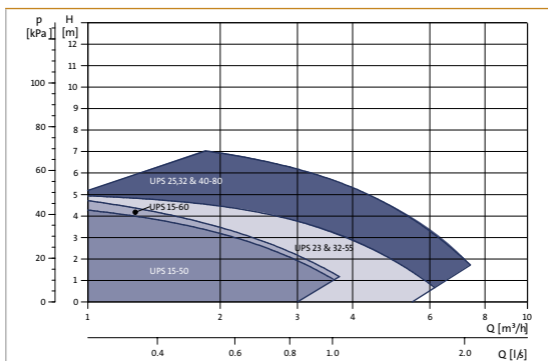

Grundfos MAGNA

– for larger heating systems



Technical data

Liquid temperature:	+2°C to +110°C
Operating pressure:	Max 0.1MPa (10bar)
Power range:	10 W to 900 W
Speed:	Variable and fixed speed (1-3)
Connections:	Unions, flanges
Port to port:	180 to 340 mm
Pump housing:	Cast iron, stainless steel
Insulation shell:	Standard

BUS communication module available

Relay module available

Energy labeling:



Performance curves

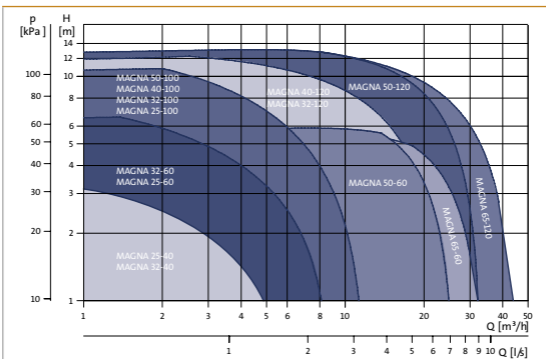

Grundfos COMFORT

– for hot water re-circulation



Technical data

Head max:	1.2 m
Flow max:	0.6 m ³ /h
Liquid temperature:	+2°C to +95°C
Operating pressure:	Max 0.1MPa (10 bar)
Power range:	25 W
Speed:	Fixed speed (1)
Connections:	Unions, Rp
Port to port:	80 and 110 mm
Pump housing:	Brass

Performance curves

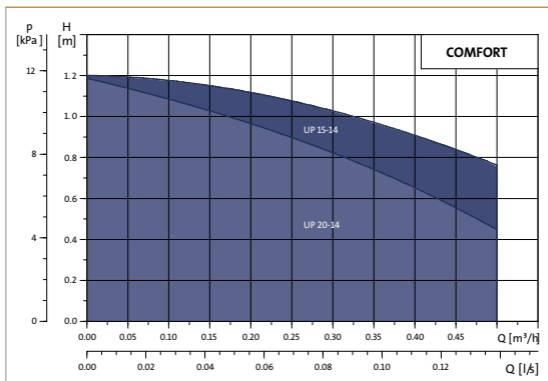

Grundfos UP – N/B Circulator

– for domestic hot water recirculation



Technical data

Liquid temperature:	+2°C to +110°C
Operating pressure:	Max 0.1MPa (10 bar)
Power range:	25W to 125 W
Speed:	Fixed speed (1-3)
Connections:	Unions, flanges
Port to port:	150, 180, 220, 250 mm
Pump housing:	Stainless steel / bronze

Performance curves

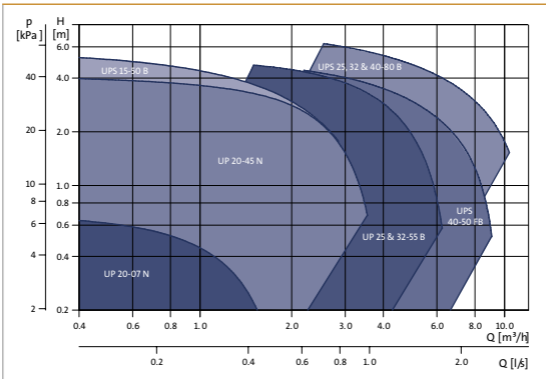

Grundfos SOLAR

– for solar systems



Technical data

Liquid temperature:	+2°C to +110°C
Operating pressure:	Max 0.1MPa (10 bar)
Power range:	35W to 230 W
Speed:	Fixed speed (1-2)
Connections:	Unions
Port to port:	130 to 180 mm
Pump housing:	Cast iron, cathaphoretic treated

Range Head (H): 4 m, 4½ m, 6 m, 6½ m, 8 m, 12 m

Performance curves

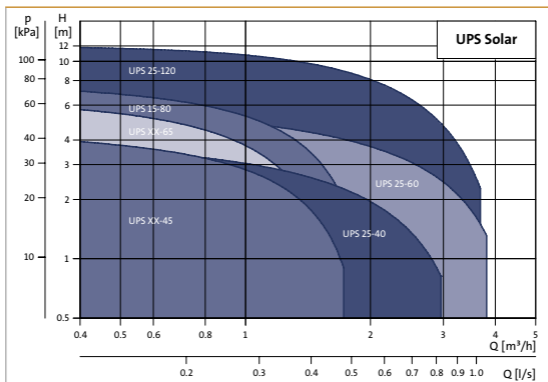

Grundfos TP

– for larger heating applications



Technical data

Liquid temperature:	-25°C to +110°C
Operating pressure:	Max 0.1MPa (10 bar)
Power Range:	120 W to 250 W
Speed:	1-speed
Connections:	1½" and 2"
Port to port:	180 mm
Pump Housing:	Cast iron, Bronze

Performance curves

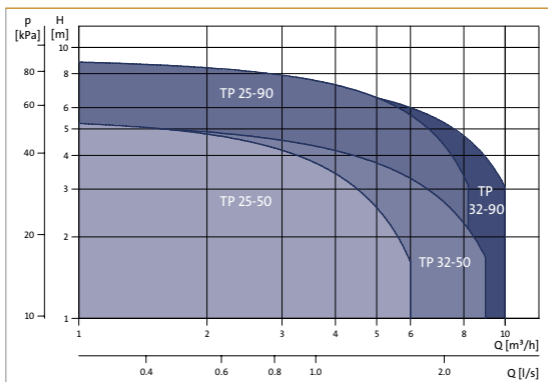

Grundfos TPE

– single stage inline pump



Technical data

Liquid temperature:	-25°C to +140°C
Operating pressure:	Max 1.6MPa (16 bar)
Power range:	Up to 22 kW
Speed:	Variable speed
Connections:	Unions, Flanges
Port to port:	180-450 mm
Pump housing:	Cast iron, bronze
Head, H:	Max 90 m

Performance curves

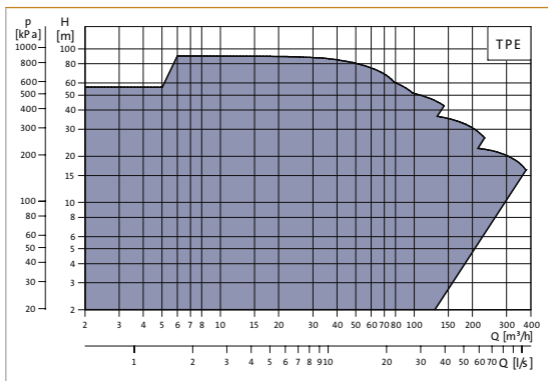

Grundfos Conlift

– for condensate removal



Technical data

Liquid temperature:	0° to +35°C
Max flow:	420 l/h
Head:	max. 5.4 m
Power Consumption:	0.080 kW
Voltage:	1x230V/50Hz
Weight:	2.4 kg
Material:	PP acid resistant pH>2.7
Reservoir size:	2.6 l

Performance curves

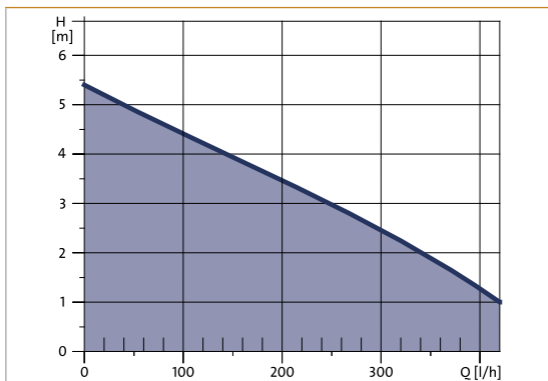

Choice of Standard Grundfos Low Energy Spare Head

For gas boilers

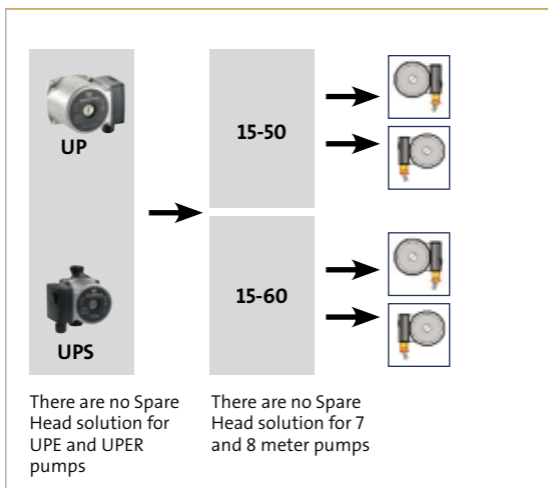



Grundfos GT tanks for hot water

Grundfos GT tanks for heating applications are suitable for a wide variety of domestic and industrial heating systems, where a controlled pressure is vital.

Grundfos supplies:

GT-HR: non-replaceable diaphragm
Capacity: 8 - 1000 l

Operating conditions:

Max. liquid temperature:	Continuous: 70° C Short periods: 99° C
Max. operating pressure:	8 - 35 litres: 3 bar 50 - 1000 litres: 6 bar
Pre-charge pressure:	1.5 bar



Sizing of heating tanks

Pre-conditions:

Heating Systems: Flat radiators, specific water volume: 11.3 l/kW. Heating system: 70/50°C.

Maximum system pressure (bar)	3	6	
Precharge pressure (bar)	1.5	3	Tank size (l.)
Heat input (kW)	3	–	8
	4	–	12
	8	–	18
	16	–	25
	27	–	35
	44	60	50
	75	100	80
	90	120	100
	130	170	140
	180	250	200
	230	310	250
	270	370	300
	370	490	400
	460	620	500
	550	740	600
730	990	800	
910	1230	1000	

Grundfos recommends:

- set the precharge pressure of the tank to at least 0.2 bar above static pressure of the heating system
- the precharge pressure of the tank should not be below 1.5 bar.

Sizing example:

A heating system has a heat input of 160 kW. Max system pressure is 6 bar. The heating system will be precharged by 3 bar.

Use the column for 6 bar max. system pressure.

The nearest value above 160 kW is 170 kW.

This corresponds to a tank size of 140 litres.

Insulation shells

The insulating thickness of the insulation shells corresponds to the nominal diameter of the pump.

The insulation kit, which is tailored to the individual pump type, encloses the entire pump housing. The two shells are easily fitted around the pump.

Insulation kits are available for UPS and ALPHA2 pumps.



Pump type	Insulation kits
ALPHA2, UPS 25-20, 32-20, 25-30, 32-30, 25-40, 32-40, 25-60, 32-60, 25-40N/B, 25-60N/B	Product No. 505821
UPS 25-20A, 25-30A, 25-40A, 25-60A	Product No. 505822
UPS 25-80, 25-80N/B	Product No. 505242
UPS 25/32/32N/32F-100/40F-100	Product No. 95906653
UPS 40-50F, 40-50FB, 32-80, 32-80N/B	Product No. 505243

Heating pumps for MAGNA is supplied as standard with insulation shells.

ALPHA/Power plug

ALPHA plug kits are available for ALPHA2 and MAGNA.



Description	Product No.
ALPHA plug	595562



The basic principles

The theoretical aspects of heating are elements we all need to deal with. Whether in the field or at the office, elementary knowledge of what is going on in the pumps and pipes is essential.

This section examines selected basic principles in heating, and presents them with a number of illustrations. These basic theoretical principles cover heat loss, flow calculation and variation, pressure loss, and more.

For specific pump selection in connection with system dimensioning, we recommend using Grundfos WinCAPS, WebCAPS and www.grundfos.co.uk.

The calculation tools found within help ensure finding the correct pump according to specific system requirements.

Heat loss

The heating system should compensate for the heat loss from the building. Therefore, this loss will be the basis for all calculations in connection with the heating system.

The following formula should be used:

$$U \times A \times (T_i - T_u) = \Phi$$

U = The transmission coefficient in $W/m^2/K$

A = The area in m^2

T_i = Dimensioning indoor temperature in $^{\circ}C$

T_u = Dimensioning outdoor temperature in $^{\circ}C$

Φ = The flow of energy (heat loss) in W

The outdoor temperature will vary depending on location.

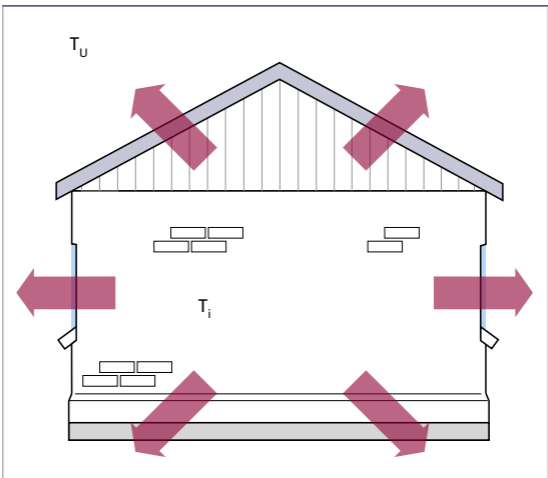

Heat demand in kW

Heated area [m ²]	Heat loss W/m ²									
	30	40	50	60	70	80	100			
60	1.8	2.4	3.0	3.6	4.2	4.8	6.0			
70	2.1	2.8	3.5	4.2	4.9	5.6	7.0			
80	2.4	3.2	4.0	4.8	5.6	6.4	8.0			
90	2.7	3.6	4.5	5.4	6.3	7.2	9.0			
100	3.0	4.0	5.0	6.0	7.0	8.0	10.0			
120	3.6	4.8	6.0	7.2	8.4	9.6	12.0			
140	4.2	5.6	7.0	8.4	9.8	11.2	14.0			
160	4.8	6.4	8.0	9.6	11.2	13.8	16.0			
180	5.4	7.2	9.0	10.8	12.6	14.4	18.0			
200	6.0	8.0	10.0	12.0	14.0	16.0	20.0			
220	6.6	8.8	11.0	13.2	15.4	17.6	22.0			
240	7.2	9.6	12.0	14.4	16.8	19.2	24.0			
260	7.8	10.4	13.0	15.6	18.2	20.8	26.0			
280	8.4	11.2	14.0	16.8	18.6	21.4	28.0			
300	9.0	12.0	15.0	18.0	21.0	24.0	30.0			
320	9.6	12.8	16.0	19.2	22.4	25.6	32.0			
340	10.2	13.6	17.0	20.4	23.8	27.2	34.0			
360	10.8	14.4	18.0	21.6	25.2	28.8	36.0			

Use of table:

1. The left column indicates heated area in m² (ground area).
2. The top row indicates heat loss in W/m².
3. The cross section defines the heat demand for the house in kW.

Flow calculation

When the energy flow Φ is known (see Heat loss), the flow pipe temperature, T_F , and the return-pipe temperature, T_R , should be determined to calculate the volume flow rate, Q . The temperatures determine the volume flow rate, as well as the dimensioning of heating surfaces (radiators, calorifiers etc.).

The following formula is used:

$$\frac{\Phi \times 0.86}{(T_F - T_R)} = Q$$

Φ = Heat demand in kW (see page 46)

Conversion factor (kW to kcal/h) is 0.86

T_F = Dimensioning flow pipe temperature in °C

T_R = Dimensioning return-pipe temperature in °C

Q = Volume flow rate in m³/h

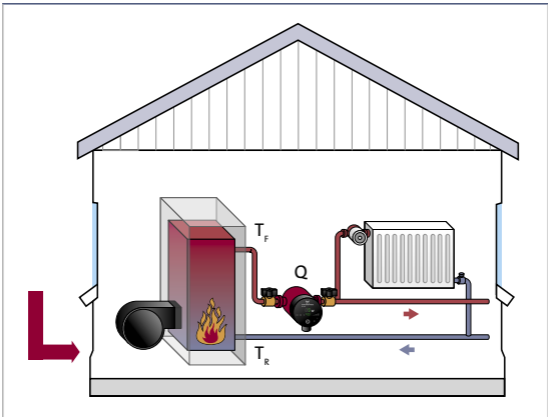

Flow demand in m³/h

Heat demand [kW]	Difference temperature ΔT							
	5	10	15	20	25	30	35	40
5	0.9	0.4	0.3	0.2	0.2	0.1	0.1	0.1
6	1.0	0.5	0.3	0.3	0.2	0.2	0.1	0.1
7	1.2	0.6	0.4	0.3	0.2	0.2	0.2	0.2
8	1.4	0.7	0.5	0.3	0.3	0.2	0.2	0.2
9	1.5	0.8	0.5	0.4	0.3	0.3	0.2	0.2
10	1.7	0.9	0.6	0.4	0.3	0.3	0.2	0.2
12	2.1	1.0	0.7	0.5	0.4	0.3	0.3	0.3
14	2.4	1.2	0.8	0.6	0.5	0.4	0.3	0.3
16	2.8	1.4	0.9	0.7	0.6	0.5	0.4	0.3
18	3.1	1.5	1.0	0.8	0.6	0.5	0.4	0.4
20	3.4	1.7	1.1	0.9	0.7	0.6	0.5	0.4
22	3.8	1.9	1.3	0.9	0.8	0.6	0.5	0.5
24	4.1	2.1	1.4	1.0	0.8	0.7	0.6	0.5
26	4.5	2.2	1.5	1.1	0.9	0.7	0.6	0.6
28	4.8	2.4	1.6	1.2	1.0	0.8	0.7	0.6
30	5.2	2.6	1.7	1.3	1.0	0.9	0.7	0.6
32	5.5	2.8	1.8	1.4	1.1	0.9	0.8	0.7
34	5.8	2.9	1.9	1.5	1.2	1.0	0.8	0.7

Use of table:

1. The left column indicates heat demand in kW.
2. The top row indicates differential temperature T in °C.
3. The cross section defines the flow demand for the pump in m³/h.

Flow variation

The maximum heat demand for the particular building is determined by the formulas on the previous pages. The maximum flow, however, will only be required for a very short period of the year.

Variations of ambient temperature, solar radiation, and the heat contributed by people, lighting and electrical equipment in the rooms will result in considerable variation in the heat demand and, consequently, the flow.

Installing thermostatic radiator valves and a speed controlled pump are the most efficient ways to deal with these variations.

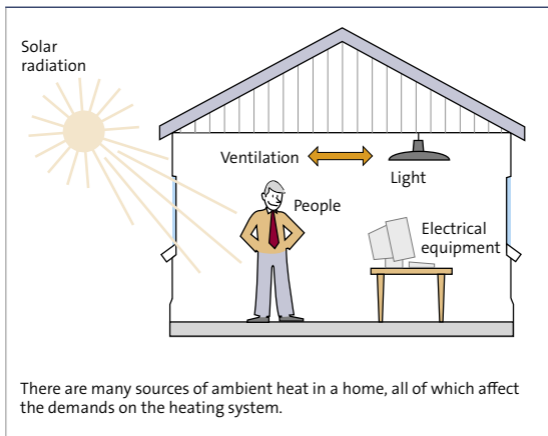

Load profile of a heating system

Based on measurement of the flow in a heating system and the average outdoor temperature, a standard flow profile and a calculation profile can be made. The calculation profile can be used for calculating the energy consumption of the circulation pump and, thus, to define the profitability of using an automatic, speed controlled, A-labelled pump. A life cycle cost (LCC) for the pump can also be created.

Max flow is rarely required

The maximum flow will normally be required for less than 6% of the year. Flow will be under 50% for 79% of the year.

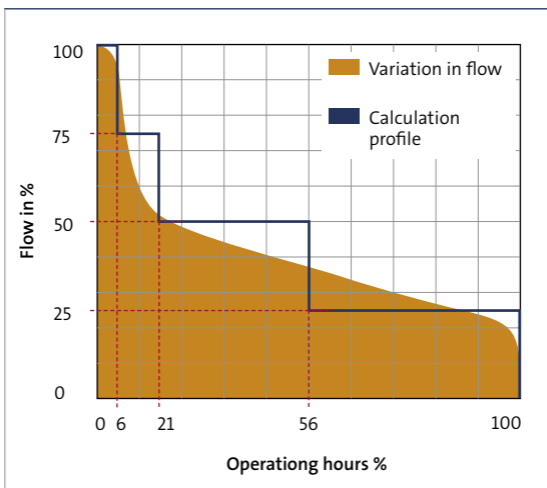

Pressure relations in a heating system

When dimensioning a heating system, it is necessary to take the system pressure as well as the pressure loss into consideration.

1. System pressure [kPa]

The overpressure present in a heating system when the circulator pump has stopped. The height of the building influences the pressure.

2. Pressure loss Δp [kPa]

The circulator pump must compensate for the loss of pressure in the system. The overall size of the system and the size of the individual components influence the pressure loss.

Please ensure that the required minimum inlet pressure is available for the circulator pump (see technical documentation or Installation instruction).

The pump duty should be selected according to the 30 kPa pressure loss (and not the 70 kPa pressure in the system!).

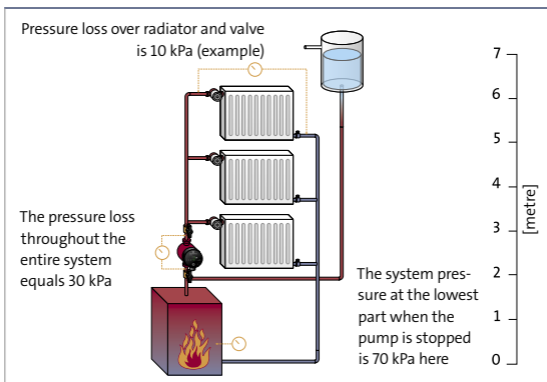

System pressure

System pressure, or the static pressure of the system, is defined as the overpressure present in the system. The system pressure depends on the construction of the system. We distinguish between two types of systems:

- Open system
- Closed, pressurized system.

The system pressure greatly influences the pumps and valves of the system. If the system pressure is too low, this increases the possibility of noise created by cavitation in the system. This is particularly a problem at high temperatures. If a canned rotor type pump is used (e.g. UPS, ALPHA2, MAGNA) please ensure that the required minimum inlet pressure is available. Check literature for recommendations.

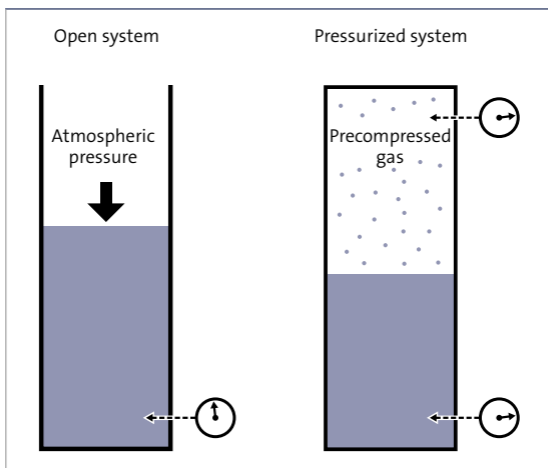

Open expansion systems

The height of the water level in the expansion tank determines the system pressure and, consequently, the pressure at the pump.

In the example below, the system pressure at the pump is approx. 1.6 m. Please check technical information for required minimum pump inlet pressure, according to pump size.

In open tank systems an expansion tank will be required.

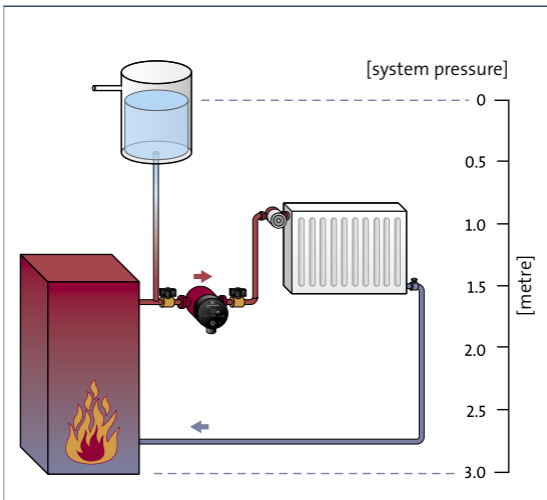

Pressurised expansion systems

A pressurised system is fitted with a pressure-expansion tank with a rubber membrane, which separates the compressed gas from the water in the system.

The system pressure must be approx. 1.1 times the inlet pressure at the tank. If the system pressure is higher, the tank loses its ability to absorb the dilation of the heated water. This may cause unwanted pressure increases in the system.

If the system pressure is lower than the inlet pressure, there will be no water reserve when the temperature in the system falls. In some cases, this may cause a vacuum to form, drawing air into the system.

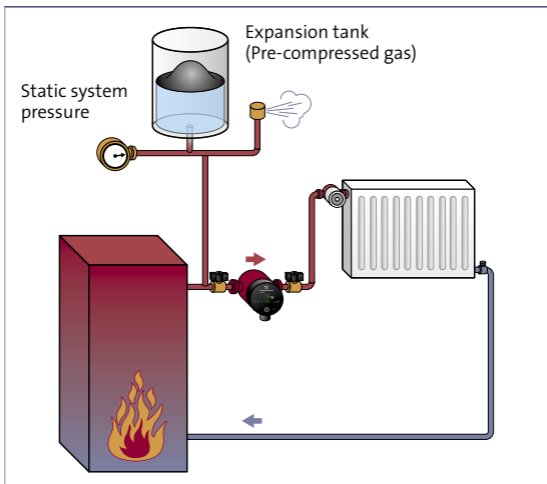

Head

Resistance has to be overcome to pump heating water through the pipes. This hydraulic resistance consists of pipe resistance and individual points of resistance. The equation

$$\Delta p = 1.3 \times \Sigma[R \times L] + \Sigma Z$$

is used to calculate the loss in pressure Δp in the equipment, whereas a 30% increase for molded parts and fixtures has already been taken into account. The relationship:

$$\frac{\Delta p}{\rho \times g} = \frac{\Delta p}{1,000 \times 10} = \frac{\Delta p}{10,000}$$

gives us the lift height H of the pump.

Or, simplified:

$$\frac{1.3 \times \Sigma[R \times L] + \Sigma Z}{10000}$$

- with:
- R = R value of the pipe in Pa/m (see page 60)
 - L = length of the least favorable segment (flow and return) in m
 - Z = individual resistances in Pa
 - Δp = pressure drop (differential pressure)
 - ρ = density of liquid (kg/m^3) Water = 1000kg/m^3
 - g = acceleration due to gravity (m/s^2)
 - ΣZ = total value of Z

The values for individual resistances can be obtained from the manufacturers specifications of the products used. If no such information is provided, the following values can be used as rough estimates:

Boiler:	1000 to 2000 Pa
Mixer:	2000 to 4000 Pa
Pa thermostat valve:	5000 to 10000 Pa
Heat quantity meter:	1000 to 15000 Pa

Component	Pressure loss
Boiler	1-5 kPa
Boiler compact	5-15 kPa
Heat exchanger	10-20 kPa
Heat meter	15-20 kPa
Water heater	2-10 kPa
Heat pump	10-20 kPa
Radiator	0.5 kPa
Convactor	2-20 kPa
Radiator valve	10 kPa
Control valve	10-20 kPa
Non return valve	5-10 kPa
Filter (clean)	15-20 kPa

All values are average values.

Pressure loss

The pressure loss in components such as boilers, pipes, and bends will increase as the flow increases. The total pressure loss of the system can be shown in a diagram as a system characteristic. If the flow is doubled, the pressure loss will quadruple. The increase in flow also increases the velocity through the components, and high velocity increases the risk of noise from the system (e.g. when Thermostatic Radiator Valves reduce or shut down). This will be prevented, by using an automatic variable speed pump, like ALPHA2 and MAGNA.

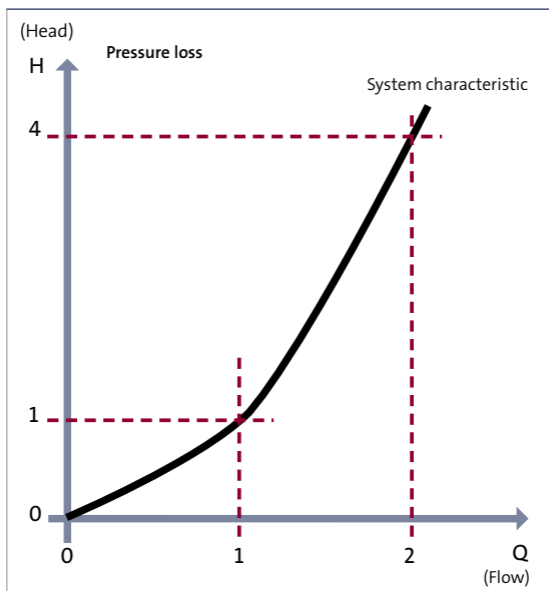

Pump curves/system characteristics

The pump curve shows the performance relationship between pressure and flow for the given pump. The duty point is where the system characteristics curve intersects with the pump curve. The duty point indicates the flow and head that the pump should provide in this system.

If the heat demand decreases, the valves in the system will close and the flow will subsequently decrease. This causes the system characteristics to change, producing a new duty point 2.

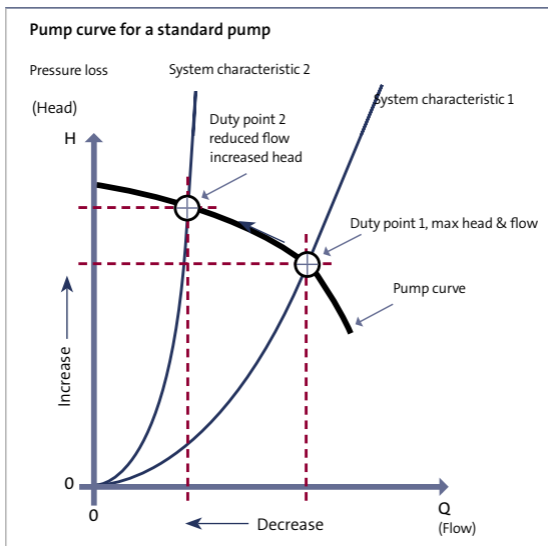

Pressure loss

Pipe dimension	Flow in m ³ /h Pressure loss in pipes [Pa/m]										Water contents [l/m]	Inside dia. [mm]
	0.1	0.5	1.0	1.5	2.0	3.0	4.0	5.0	6.0			
3/8"	79	1459	-	-	-	-	-	-	-	-	0.12	12.5
	24	445	1563	-	-	-	-	-	-	-	0.20	16.0
	6	105	369	769	1269	-	-	-	-	-	0.37	21.6
1"	2	35	122	254	427	892	1502	-	-	-	0.58	27.2
	0	9	32	67	112	234	395	592	824	-	1.01	35.9
	0	4	15	32	54	113	190	285	396	-	1.37	41.8
CU 10 x 1	602	-	-	-	-	-	-	-	-	-	0.05	8.0
	209	3499	-	-	-	-	-	-	-	-	0.08	10.0
	60	1006	-	-	-	-	-	-	-	-	0.13	13.0
CU 18 x 1	22	375	1263	-	-	-	-	-	-	-	0.20	16.0
	8	130	437	890	1473	-	-	-	-	-	0.31	20.0
	3	45	151	308	510	1038	-	-	-	-	0.49	25.0

This table is used to determine the projected pressure loss in a pipe system in Pa/m at a water temperature of 60°C. Recommended max. pressure loss is 105 Pa/m.

Balancing a heating system

Even two-pipe heating systems need balancing. At the connection point, there will normally be a variation in the differential pressure. This must be levelled out by means of lockshield valves installed on the return side of the radiators or installed in the return pipe.

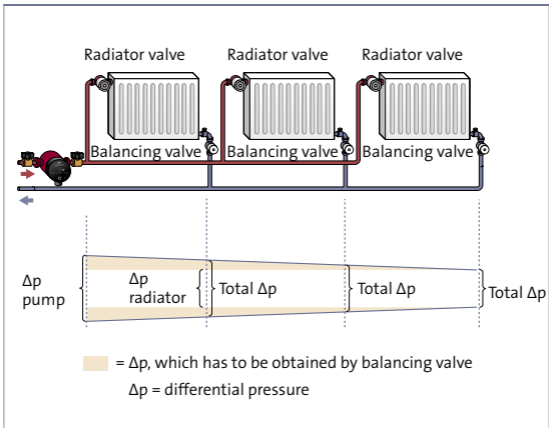

Static pressure

The static pressure must always be greater than the ambient pressure. This applies to all points in the system. Doing so ensures that air cannot enter the heating system externally.

Maintaining pressure does not mean maintaining constant pressure, however. When the hot water warms up and expands, the nitrogen in the diaphragm tank is compressed, causing pressure to rise.

Operation of a diaphragm tank with a pre-pressure (P_0) of 1 bar

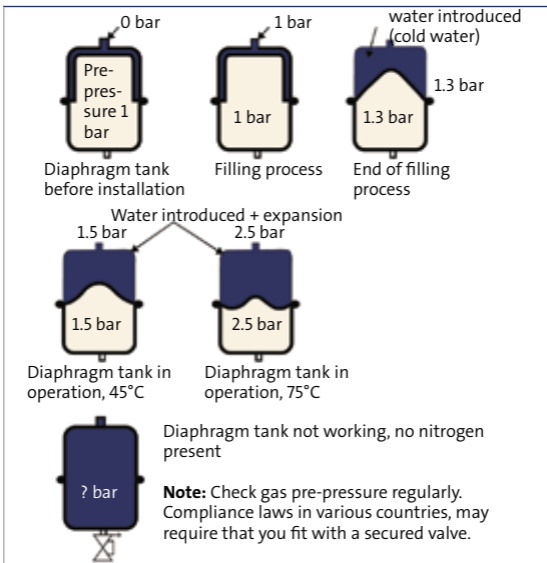

Pre pressure (P_o)

The pre-pressure of the gas in the expansion tank is determined by:

- the static height
- the minimum inlet pressure of the circulator pump.

Installation note: In systems with low geodetic heights and boilers in the roof, the required minimum inlet pressure is a critical factor.

Recommended pre-pressure setting:

Detached and semi-detached houses with system heights h_A up to 10 m, $P_o + 1$ bar
 $p_o = 1$ bar

system heights h_A over 10 m
 $p_o = (h_A/10 + 0.2)$ bar

Tasks of the diaphragm tank

- Maintain pressure within permitted limits
- Introduction of water, compensation of water losses
- Balance the varying water volume in the heating system, dependent on operating temperature.

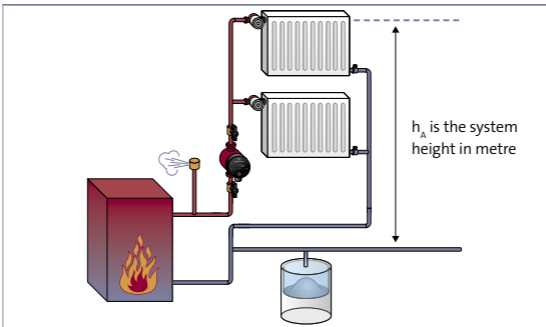

66 NOTES



Heating circulators

Starting up the pump

To avoid problems with noise resulting from air in the system, it is important to vent the system correctly:

1. Fill the system to correct static pressure (see page 62 for further information)
2. Vent the system.
3. Start the boiler.
4. Start the pump and open the radiator valves to make sure there is flow in the system.
5. Let the pump run for a few minutes.
6. Stop the pump and vent the system again.
7. Check the static pressure and refill if the pressure is too low (see the table below).
8. Start the pump again and adjust the setting if necessary.

Liquid temperature	Minimum inlet pressure
75°C	0.5 m
90°C	2.8 m
110°C	11.0 m

Useful pump tips

For installation of Grundfos circulator pumps for heating systems

These tips apply to the following products:

1. ALPHA2
2. UPS
3. UPS Solar

- Wet-rotor pumps must always be mounted with the shaft in horizontal position.
- Never install a larger pump than necessary; pump noise in the system can result.
- Never start the pump before the system is filled with water and properly vented. Even short periods of dry-running can damage the pump.
- Before starting the pump, flush clean water through the system to remove all foreign material.
- Always point the cable entry/plug downwards to prevent water from entering the terminal box.
- The pump inlet should be placed as close as possible to the expansion tank if installed.
- Make sure it will be possible to vent the pump and the pipe system when making the installation. If this is not possible, install a pump with an air separator.

- In closed expansion systems, if possible, place the pump at the return pipe due to the lower motor temperature.
- Do not install a circulator pumps with a thermostat too close to water heaters or storage tanks. Heat transfer may affect the thermostat.
- Pump head may be repositioned according to spatial dwells in the installation.

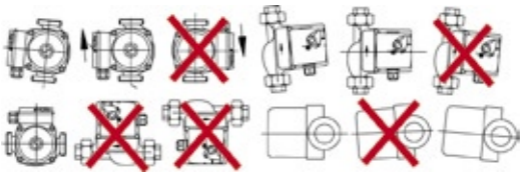

Acceptable installation positions for Grundfos circulators. However diagram 3 (pumping down) would be acceptable



Placement options for pump head

Domestic secondary hot water return

Starting up the pump

Air in the system will cause noise during operation. Venting the system correctly will eliminate this situation:

1. Turn on the water supply.
2. Open a tap at the end of the system until all air is removed from the system.
3. Start the pump and let it run for a few minutes.
4. If there is still air in the system, stop and start the pump 4-5 times until all air has been removed.
5. For Grundfos Comfort model only: Set the timer and/or the thermostat.

Useful pump tips

For installation of Grundfos circulator pumps for Domestic Secondary Hot Water Return

- Wet-rotor pumps must always be mounted with the shaft in horizontal position.
- Never start the pump before the system is filled with water and properly vented. Even short periods of dry-running can damage the pump.
- Before starting the pump, flush clean water through the system to remove all foreign material.
- Always point the cable entry/plug downwards to prevent water from entering the terminal box.
- It is preferable to install the pump on the return pipe, but if on the flow pipe, ensure the pump is pumping upwards and an air separator is installed to remove any residual air present.
- Where the water is hard, it is recommended to install a dry-runner TP pump.

Fault	Cause	Remedy
1. Noise from radiator	a) Excessive pressure passing the thermostatic valve.	Install a speed-controlled pump. System pressure will decrease as flow decreases, eliminating the noise.
2. The radiator is not giving off any heat	a) The thermostatic valve is jammed or blocked by debris.	Shut off all other radiators in the system, and set the pump at maximum speed.
	b) The heating system is imbalanced.	Re-commission the system. Fit new commissioning valves on all radiators (may be integrated in the thermostatic valves) to enable an even distribution of the flow.
3. A non speed-controlled pump will not start	a) Deposits have built up in the pump.	Set the pump on speed 3 and start. The momentum will be sufficient to remove the deposits.

Fault	Cause	Remedy
4. Pump generates too little (no) output	a) Motor is rotating backwards	In three-phase pumps, switch two phases
	b) Incorrect discharge direction imbalanced.	Turn pump 180°
	c) Dirty impeller	Open pump and clean impeller. NOTE: Close valve
	d) Suction port blocked	Open pump and clean housing. NOTE: Close valve
	e) Valve closed	Open valve (check spindle)
	f) Dirty strainer	Clean strainer
	g) Air in the pump	Switch off pump and vent. Set up gravity brake
	h) Pump at lowest speed level	Set pump to higher speed level
	i) Automatic bypass valve setting too low	Set automatic bypass valve to higher pressure. Close bypass
	j) Pump set point is too low	Increase set point on the pump or control

Fault	Cause	Remedy
5. Pump stopped, no power	a) Power supply interrupted	Check the power supply. Attach external power control if necessary
	b) Fuse tripped unbalanced.	Repair short-circuited wire. Repair loose contact. Check fuse values. Check pump motor and lead
	c) Motor starter has engaged	Clean blocked or slow-rotating pumps. Set motor rated current. Check viscosity. Repair 2-phase operation. Replace defective pump

Fault	Cause	Remedy
<p>6. Pump stopped, power supply present</p>	<p>a) Thermal switch has actuated</p>	<p>Reduce ambient temperature. Clean blocked or slow rotating pumps.</p>
	<p>b) Thermal switch has “tripped”.</p>	<p>Check viscosity. Repair 2-phase operation. Replace defective pump</p>
	<p>c) Pump does not start</p>	<p>Unblock pump. Clean pump. Increase speed/set point. Replace capacitor. Repair 2 phase operation Replace defective pump</p>
<p>7. Noises in system, thermostatic valves/pipes.</p>	<p>a) Pump output too high</p>	<p>Reduce speed level. Open bypass/valve. Hydraulic equalisation. Check pump selection/system Adjust pump Check system/guages Replace pump</p>

Fault	Cause	Remedy
8. Noisy pump	a) Air in the pump	Vent pump Vent and top up system Check expansion tank Install air separator
	b) Cavitation sounds unbalanced.	Increase pre-pressure Reduce temperature Throttle back pump Reduce speed
	c) Resonance noises	Use sound insulation material between the pump and surface to reduce resonance noise. Install expansion joints. Adjust pump speed. Adjust system's natural frequency. Replace pump/motor
	d) Knocking from foreign bodies in the pump/or on valve cones	Clean impeller. Replace non-return valve. Adjust valve pressure. Adjust valve spring. Secure valve cone. Turn valve around. Replace pump

Find detailed information via the UK website

The Grundfos UK website provides direct access to detailed product information in our WebCAPS database. Simply follow the steps below.

1. Visit the www.grundfos.co.uk website.
2. Locate the “on line” service menu on the home page.
3. Once the intro is completed, you have access to lists of general product information via any of these links in the top bar: “Water supply”, “Heating”, “Wastewater”, and “Total product list”.
4. Select WebCAPS for detailed information on Grundfos products.

Grundfos also have an online training facility called the GPlus Ecademy, visit www.grundfos.co.uk/gplus to find out about the courses available and how to sign up.

Question:

When is it necessary to adjust a Grundfos ALPHA2 pump?

Answer:

The ALPHA2 in the factory setting fits more than 80% of the heating systems.

Exception:

When a Grundfos ALPHA2 pump is used for underfloor heating, with >120 m pipe circle, it can be necessary to adjust the factory setting to a higher (constant) pressure, due to a high pressure loss in the pipes. With a maximum pipe length up to 90 m, the factory setting will be sufficient.

Example:

The longest pipe in an under-floor heating system is 120 m. With a pressure loss at 0.017 m per metre pipe, the total pressure loss (incl. valve and manifold) will be more than the 2 metres, which the factory setting provides with low flow.

Grundfos ALPHA2 settings:

Two pipe system, under-floor heating and manual bypass valve



One pipe system



Bypass commissioning



Pump venting



Automatic bypass valve



Above settings apply for most systems as described. However, the instruction manual should always be read before installation.

Question:

Is it OK to stop a pump for long periods?

Answer:

Yes, high quality Grundfos A-labelled pumps can be stopped for long periods without any problems (typically during the summer months).

When turned back on, their very high starting torque loosens any deposits that may have built up. This functionality ensures high reliability and a long pump lifetime.

For non speed-controlled pumps will it be necessary to set the pump to speed 3 in order to ensure sufficient momentum to start the pump.



Question:

Can a speed controlled pump be used for all heating systems?

Answer:

No. The heat source plays an important role. The integrated pump in a wall-mounted gas boiler cannot be replaced with a standard speed-controlled pump.

Heat sources vs pump type. pump type:

System type	ALPHA2	Spare parts*
Oil boiler	X	
Electrically heated boiler	X	
Gas boiler with integrated pump		X
Gas boiler without integrated pump	X	
Heat exchanger	X	
Direct district heating	X	
Heat pump	x	
Alternative fuel boiler	X	

Grundfos recommends ALHPA2 for these applications, but other pumps may be used. See page 7 for additional information.

* Standard Grundfos Low Energy Pump heads only for Standard Grundfos circulators in gas boilers.

Question:

Why must a non return valve be fitted on the discharge side of circulator pumps?

Answer:

Domestic hot water may only reach the tapping points via the riser main. Without a non-return valve, domestic hot water can flow through the circulator pipe and circulator pump to the tapping points. The following problems could result:

- Cold water might enter and pass through the recirculation pipe – and this could form condensation in the pump. The system water temperature must always be higher than the ambient room temperature.
- A circulator pump with a thermostat (e.g. the Grundfos COMFORT UP 20 – 14 BXT) would immediately be switched on.
- All measures taken to achieve economic operation of the circulator system would be ineffective.

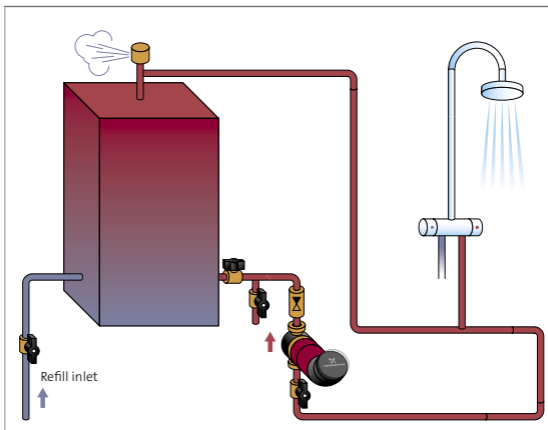

Question:

How can I remove air from my system? .

Answer:

An air Eliminator, fitted directly in the boiler flow pipe (and deliberately not at the uppermost position), uses a particular physical effect in the boiler. The water directly next to the wall of the boiler is heated to approx. 135°C and the gases contained in it are released. These gas bubbles are then removed from the system by the air eliminator directly in the boiler flow pipe.

After the air eliminator, the flow pipe water is ready to absorb gas. The water is, so to speak, “hungry for air”. Here, where air and other gases gather in the system, they are absorbed by parts of the heating water, even at upper levels, and during the next passage through the boiler they are removed from the system in collaboration with the air eliminator.

Installation note:

Gas bubbles cannot be removed in this way in systems where the geodetic system height is above 15m. For such systems, the industry can provide appliances that can de-aerate by means of pressure reduction as far as the negative pressure range.

Question:

I fitted a bigger pump in an attempt to solve a problem with poor heating performance. Why does the room still not heat up?

Answer:

Providing merely a greater flow will only produce a small change in heating output. The increased velocity does not allow for sufficient radiation of the heat found in the hot water. A high return-pipe temperature has significant disadvantages for the calorific heat value as well. Conversely, a smaller flow allows the hot water to cool down. The lower return-pipe temperature has an immediate, positive effect on the calorific heat value. See the illustration below to examine these principles.

A heating surface supplied with only 50% of system capacity has gains approximately 80% of the heat found in the system. Radiator operation curve of a room heating surface with the radiator exponent $4/3$ (e.g. radiators and panel radiators).

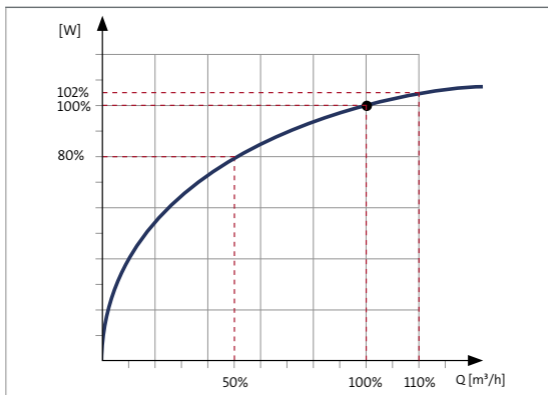

Question:

How do I equalise the pressure in a heating system?

Answer:

By using thermostat valves; either preset or adjustable.

The thermostatic radiator valve differential pressure, will vary according to the length and nature of the piping system. Whistling will occur if the pressure is too high. Excessive flow can cause velocity noise, while unfavourably situated radiators remain cold.

As a rule of thumb, the following applies:

- The head should be large; however the resistance value must not exceed 150 Pa/m.

Note: Select a pipe size larger and the resistance is reduced by up to 75%.

- Flow through pre-set thermostatic valves, with a small heat output (up to 0.5 kW), can be limited as follows:
 - = small setting value, medium heat output (approx. 1 kW)
 - = medium setting value, high heat output (approx. 2 kW)
 - = high setting value.
- Do not use an overflow valve. Use an automatic variable speed pump instead, ie Alpha2.

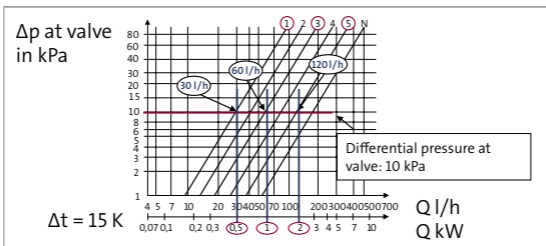



Addresses

Head Office

Grovebury Road
Leighton Buzzard
Beds.
LU7 4TL
Tel: 01525 850000
Fax: 01525 850011
E-mail : uk-sales@grundfos.com
Website: www.grundfos.co.uk

Leigh Office

Orford Court
Greenfold Way
Leigh
Lancs
WN7 3XJ
Tel: 08707 503888
Fax: 01942 605970

Livingston Office

Kirkton Campus
Fleming Rd
Livingston
West Lothian
EH54 7BN
Tel: 01506 461666
Fax: 01506 461555

Grundfos Control Solutions

Fairacres Industrial Estate
Unit A1
Dedworth Road
Windsor
Berks
SL4 4LE
Tel: 01525 850000
Fax: 01753 832335

BE > THINK > INNOVATE >

Be responsible
Think ahead
Innovate